

Actuating Plate L200

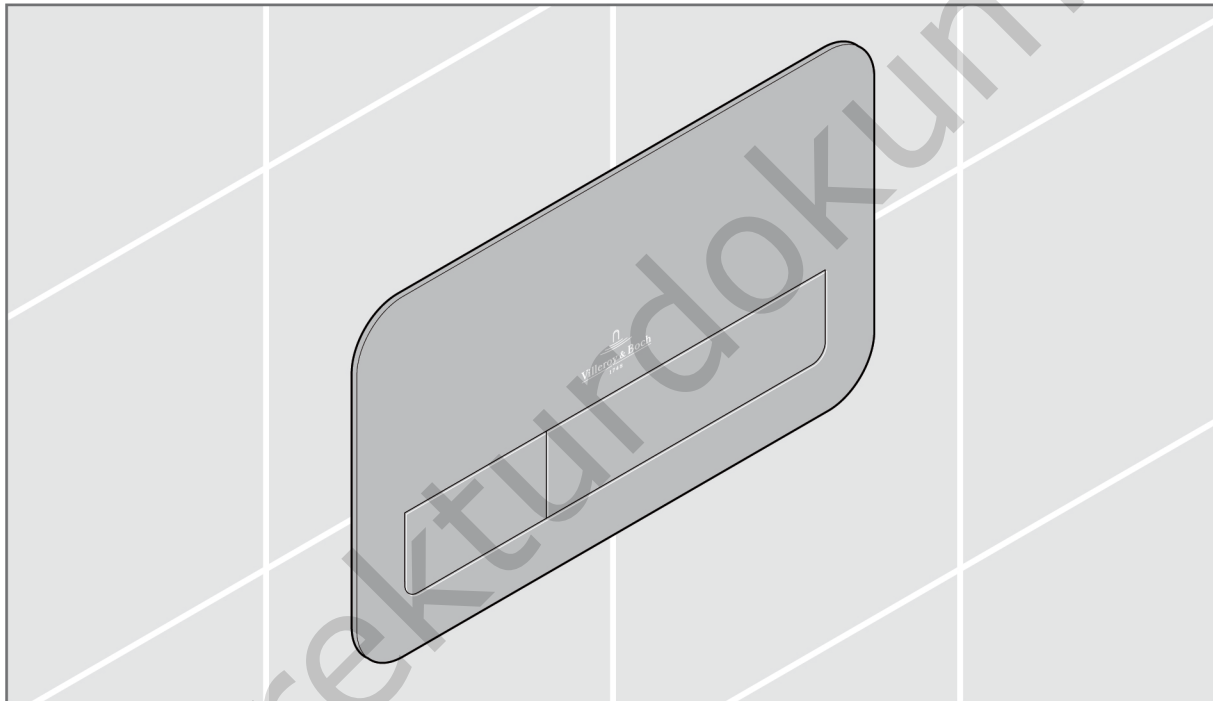

- DE Montageanleitung
- ES Instrucciones de montaje
- FR Instructions de montage
- IT Istruzioni per il montaggio
- NL Montagehandleiding
- RU Инструкция по монтажу

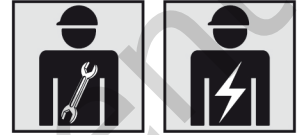

Sicherheit



Warnung!

Stromschlag durch Berühren stromführender Komponenten!

Schwere Verletzungen bis hin zum Tod können die Folge sein.

- Den Netzanschluss ausschließlich von einer Elektrofachkraft ausführen lassen.
- Sicherstellen, dass während der Arbeiten die Leitung stromfrei geschaltet und gegen Wiedereinschalten gesichert ist.
- Den Netzstecker nicht mit nassen Händen einstecken oder abziehen.

Sämtliche Arbeiten an elektrischen Anschlüssen dürfen nur von einer Elektrofachkraft gemäß den elektrotechnischen Regeln durchgeführt werden.

Installation

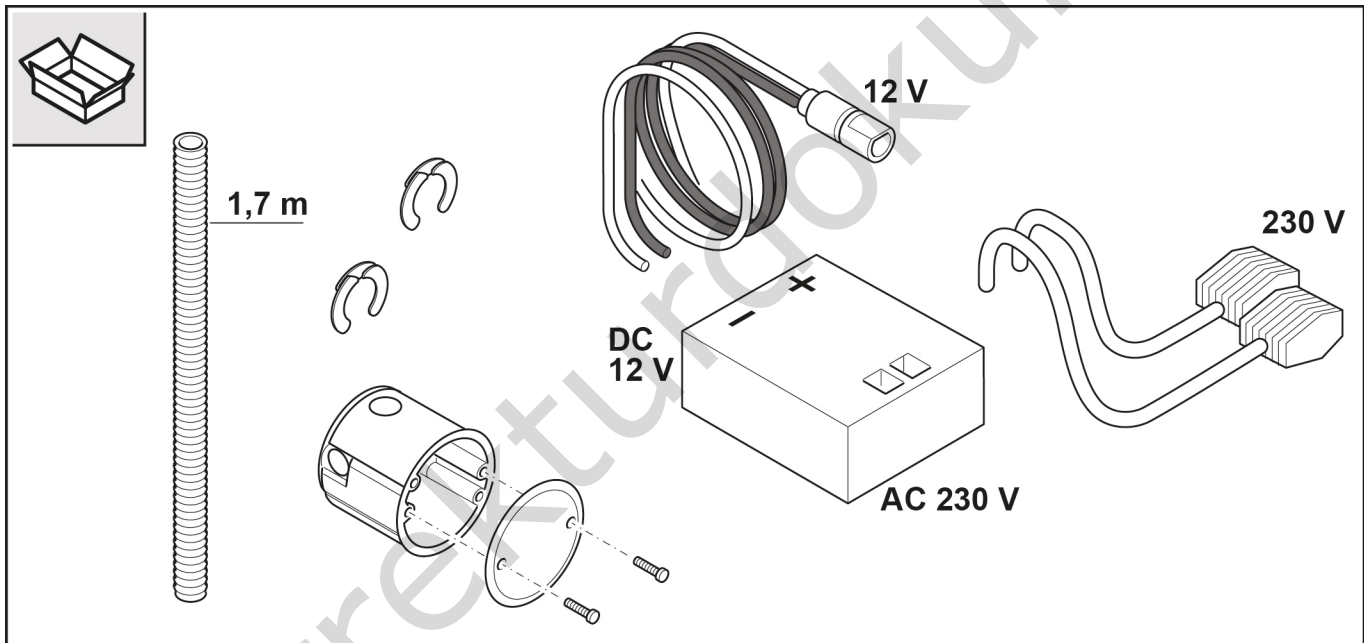

1. Festlegen des Montageorts der Unterputzdose.
 - ⇒ Unsere Empfehlung, überhalb des Spülkastens, siehe Bild 1.

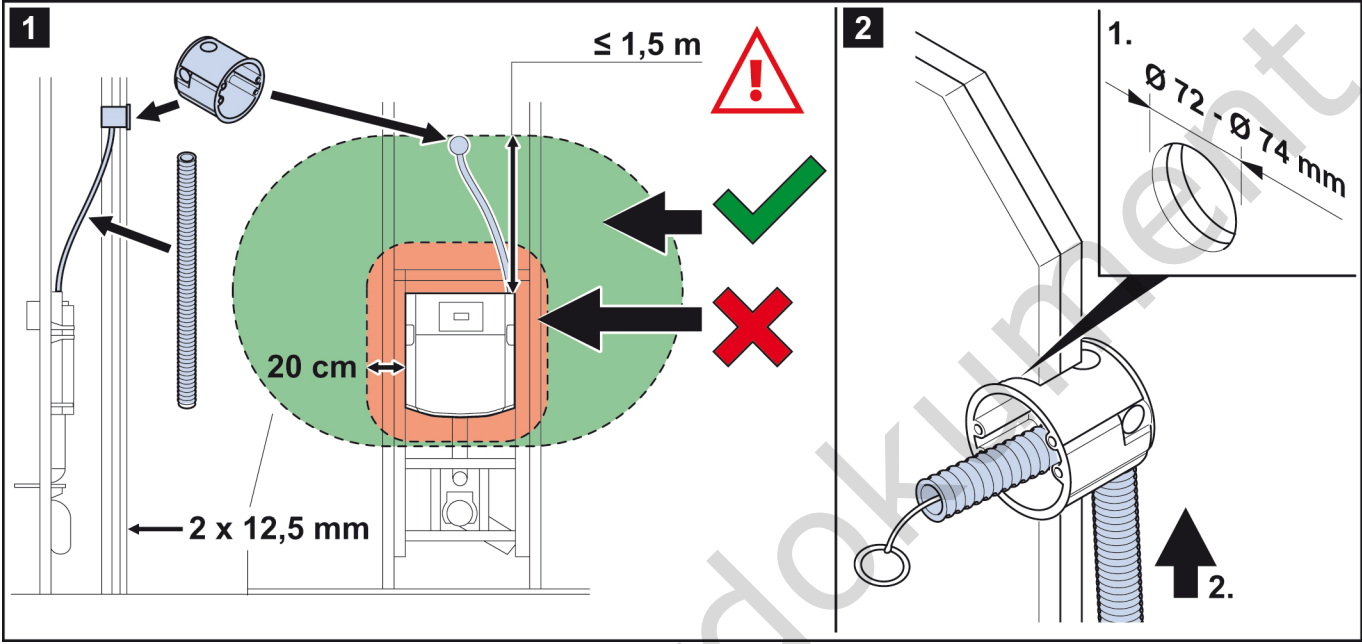

2. Einbauen der Unterputzdose.
3. Beiliegendes Leerrohr von der Unterputzdose zum Spülkasten verlegen, siehe Bild 2.

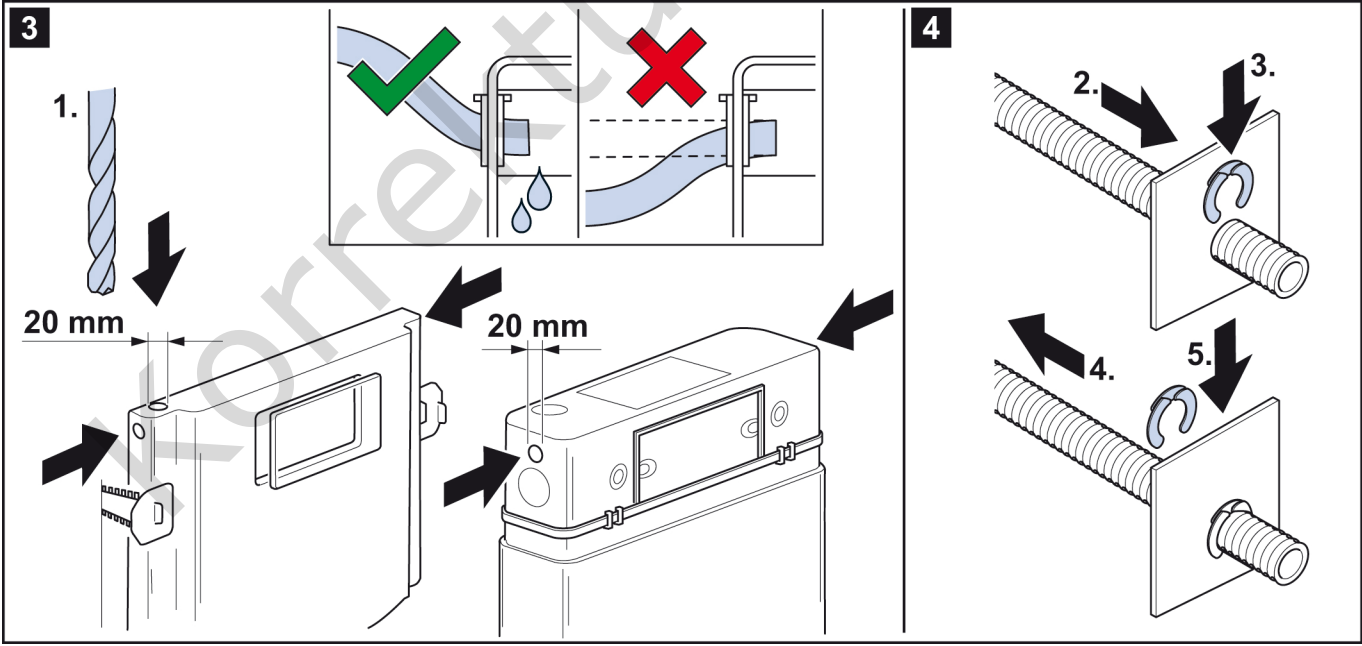

Drückerplatte montieren

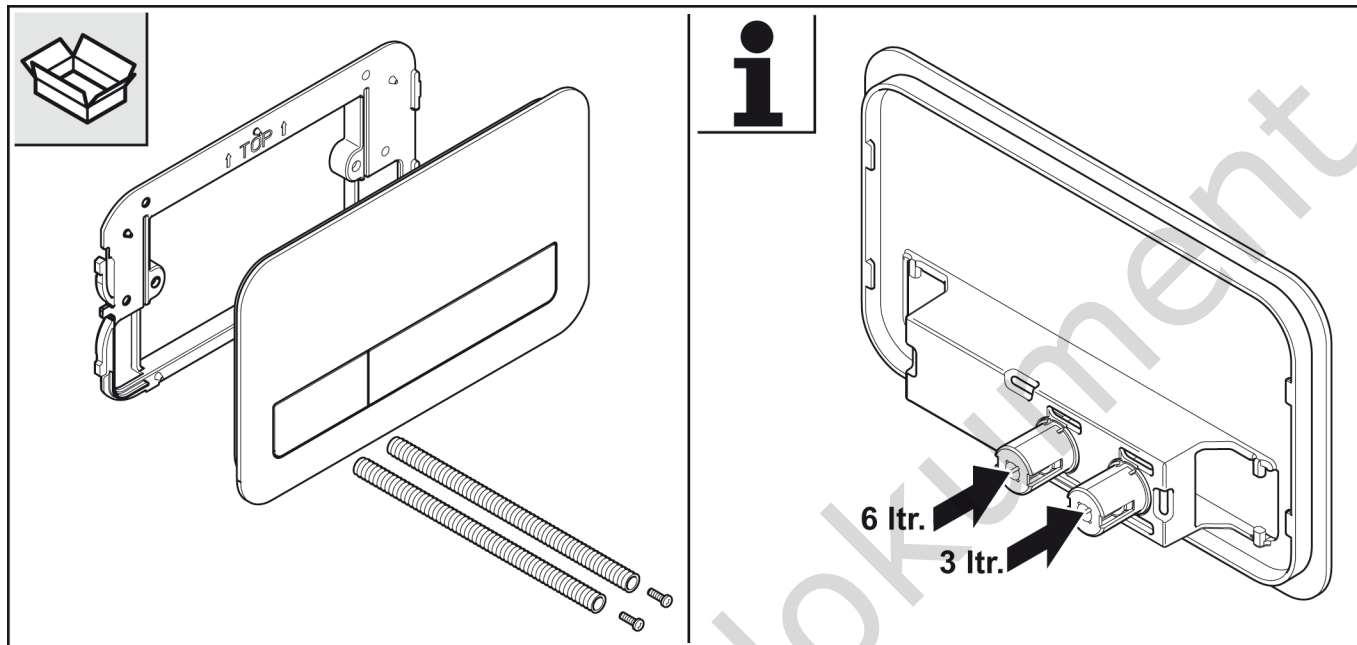

1. Trägerplatte anschrauben.

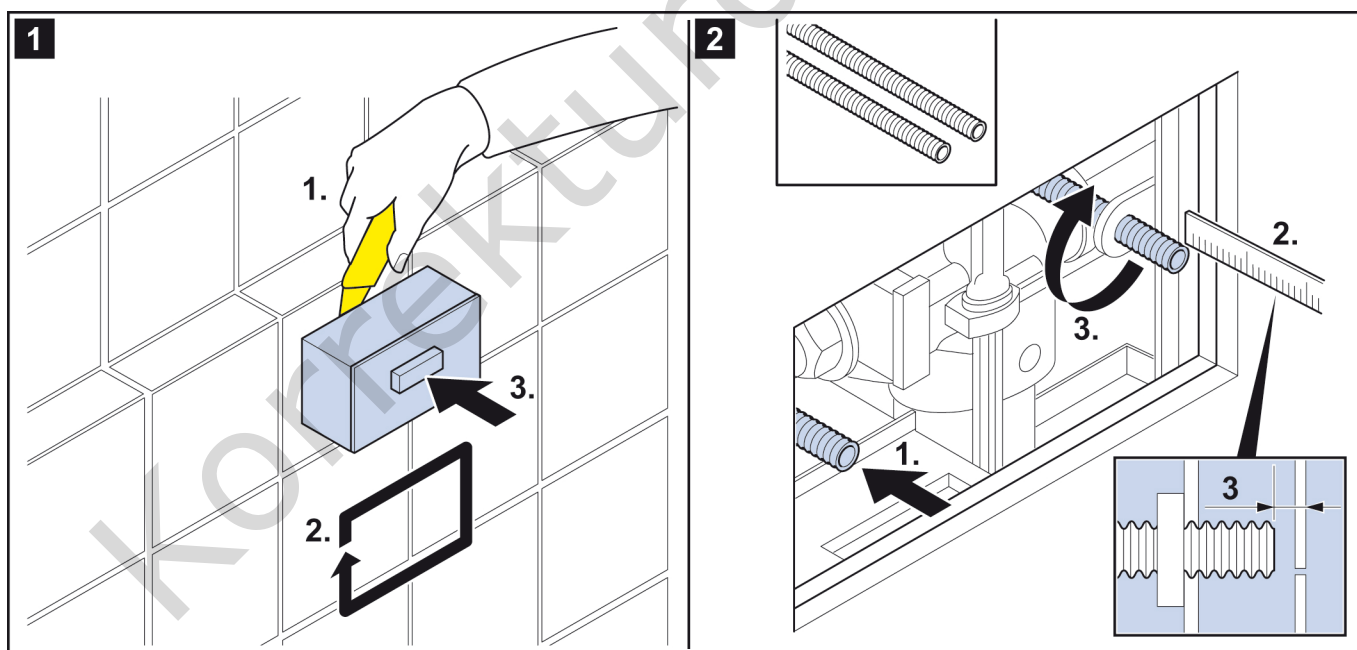

2. Stecker mit Buchse verbinden, siehe Bild 3 und 4.

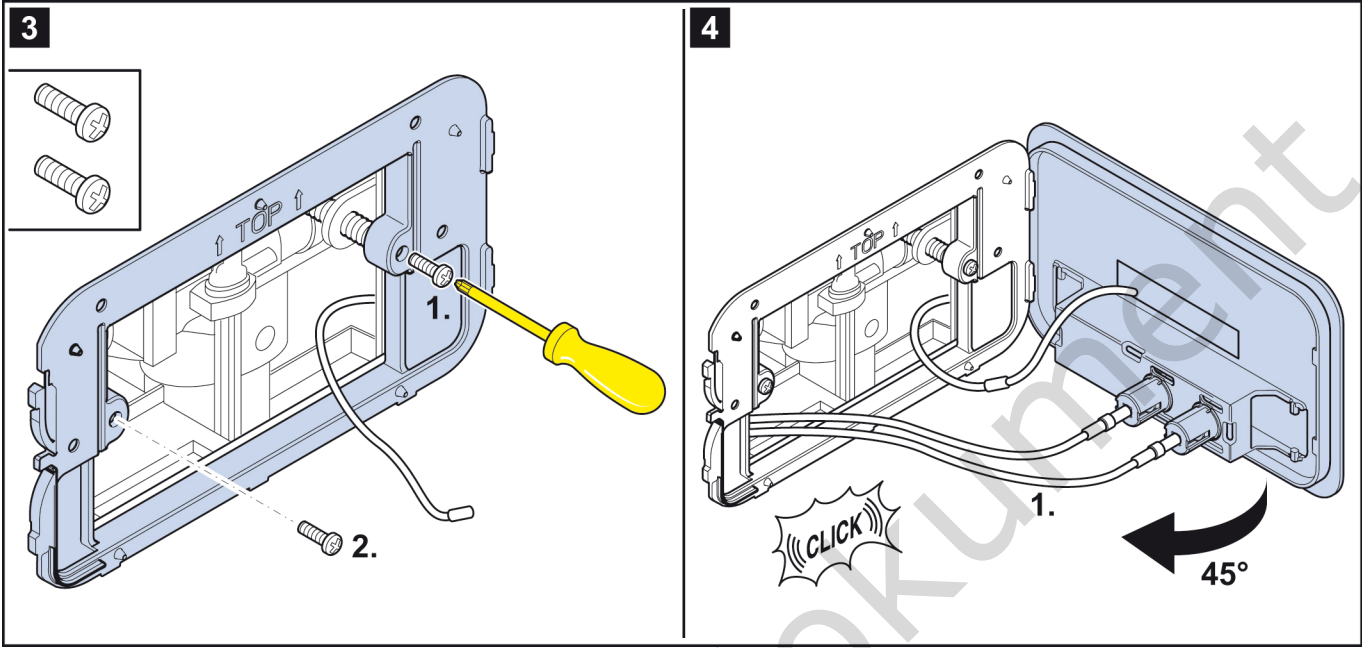

3. Drückerplatte einbauen, siehe Bild 5.

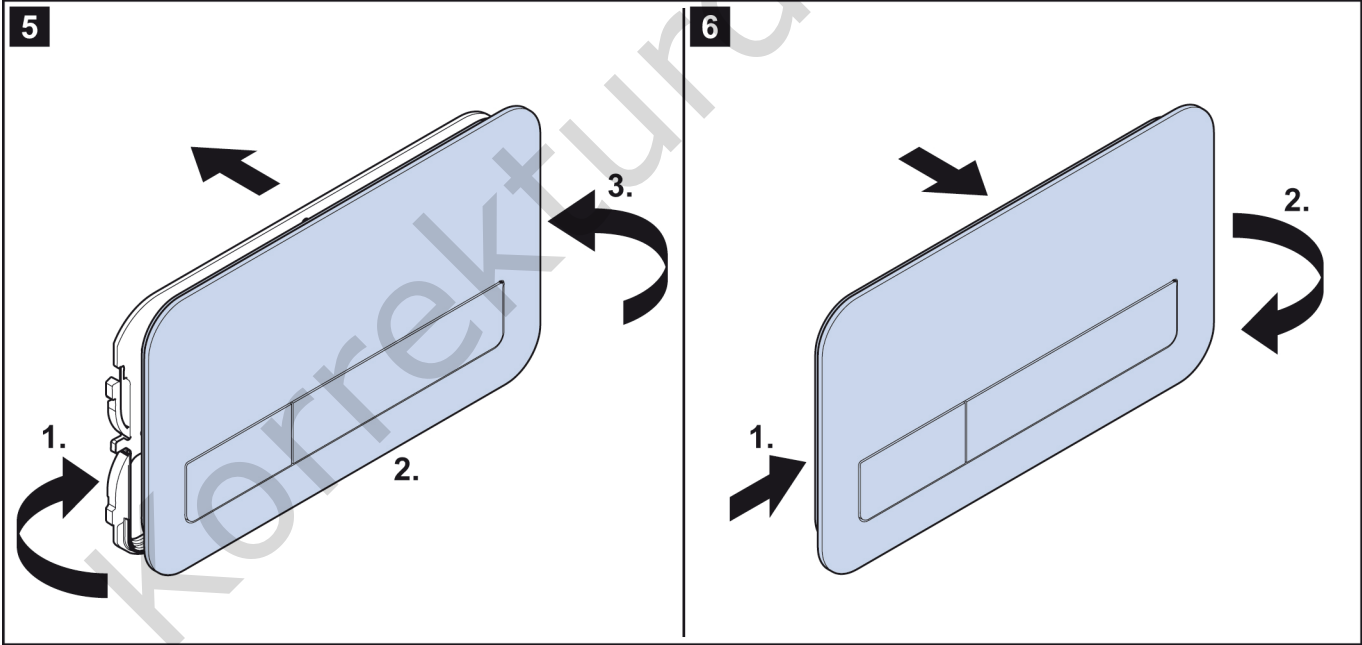

Reinigung

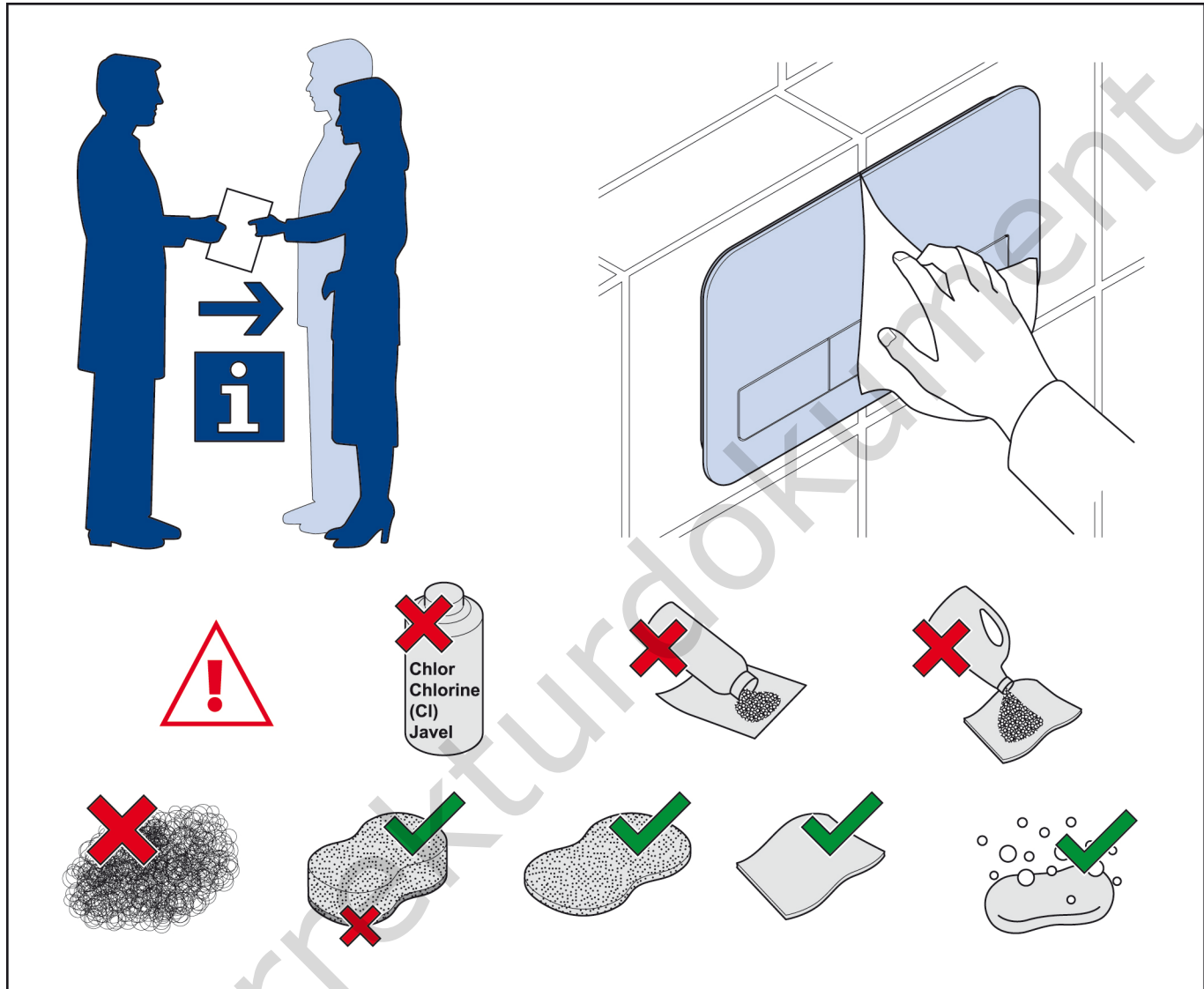

CE

EAC

Safety



Warning!

Electrocution from touching live components!

Severe injury and even death can be the consequences.

- The mains connection must be made exclusively by electricians.
- When carrying out work, make sure that the power lead is disconnected from the mains and secured against reconnection.
- Do not insert or pull out the mains plug with wet hands.

All work on the electrical connections must only be carried out by an electrician in accordance with the electro-technical regulations.

Installation

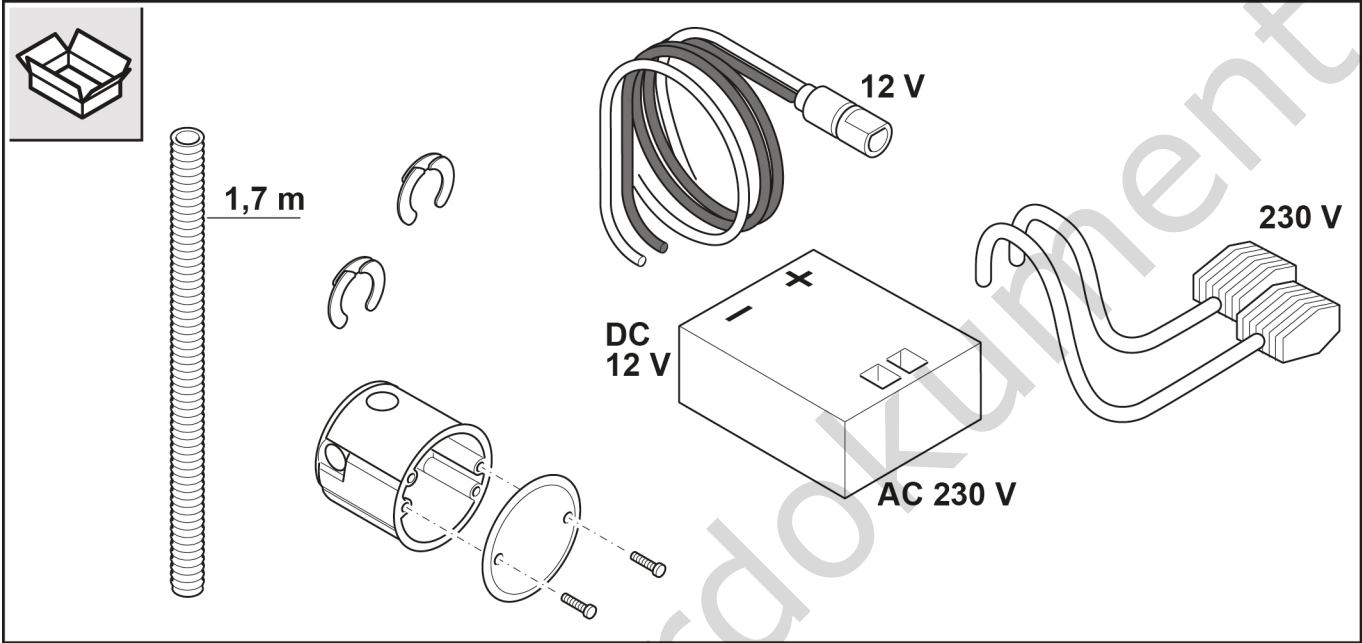

1. Determination of the installation location for the flush-mounting socket.
⇒ Our recommendation, above the flushing tank, see Illustration 1.

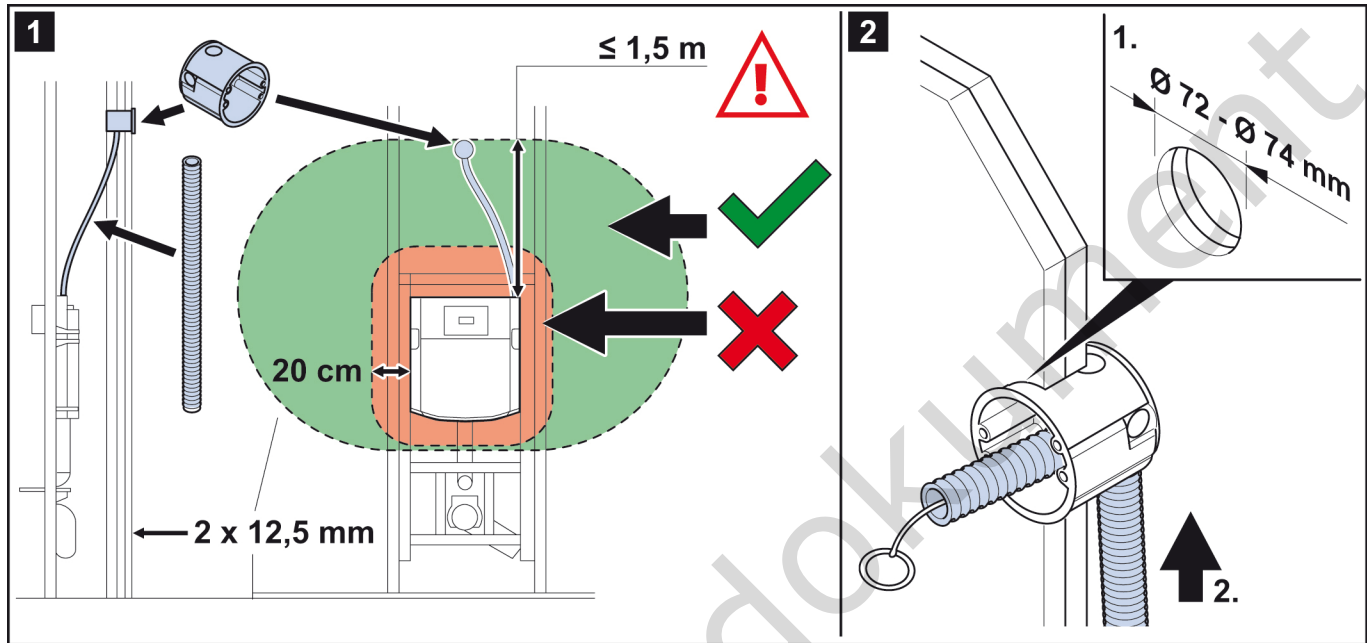

2. Installing the flush-mounting socket.
3. Route the included empty tube from the flush-mounting socket to the flushing tank, see Illustration 2.

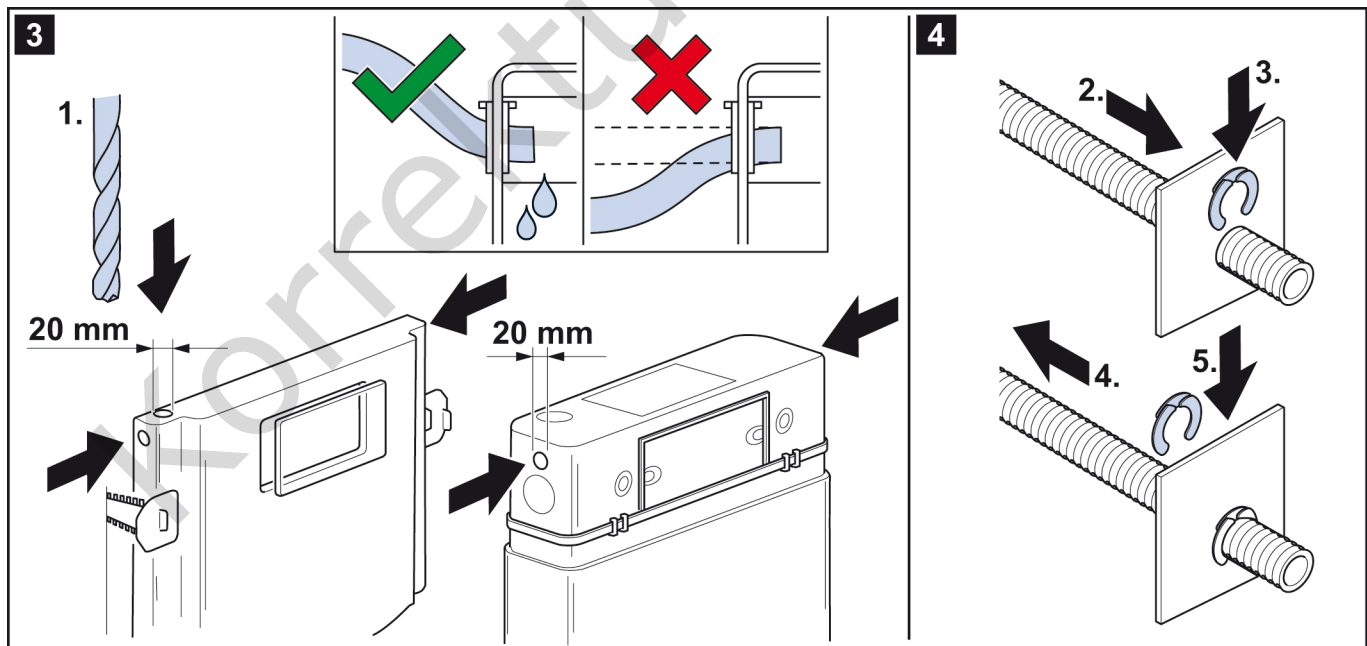

Mount the push plate

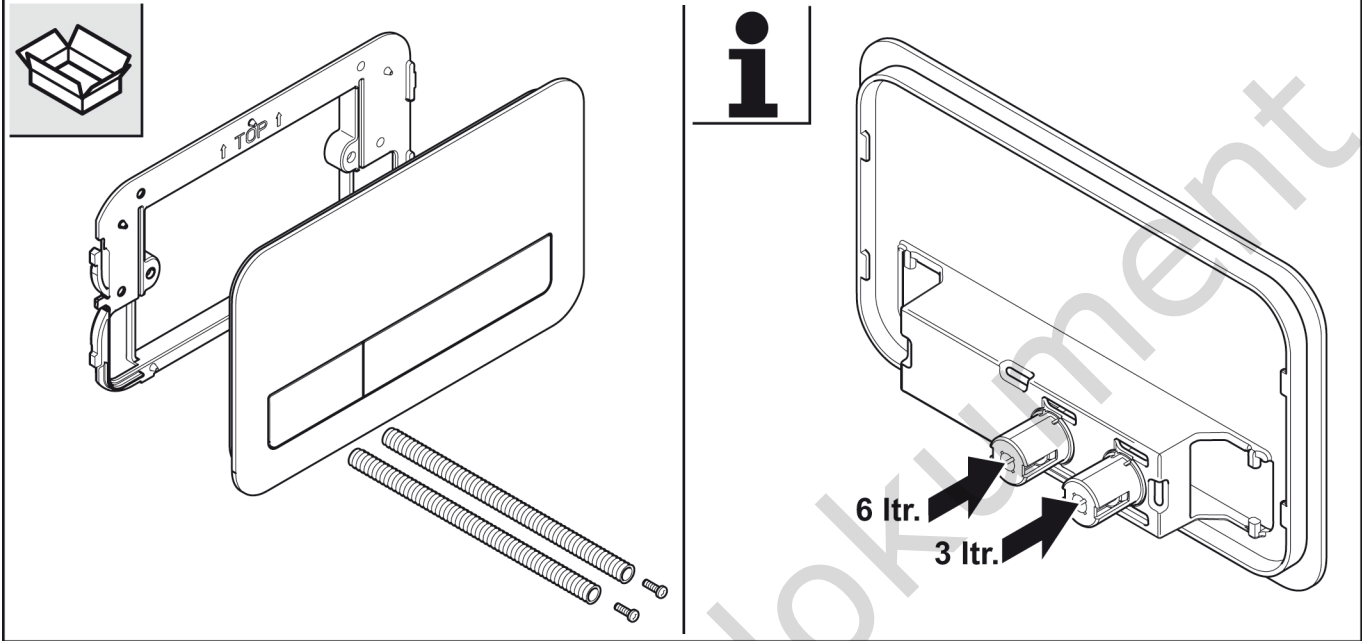

1. Screw the carrier plate in place.

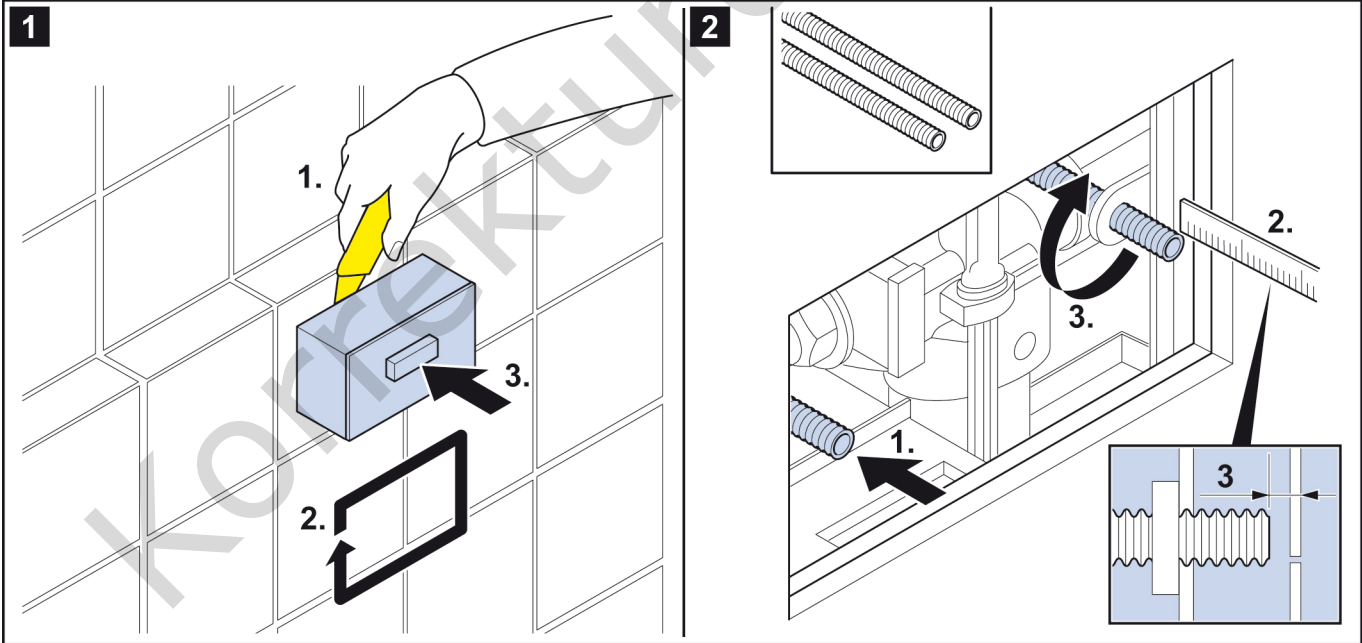

2. Connect the plug to the socket, see Illustrations 3 and 4.

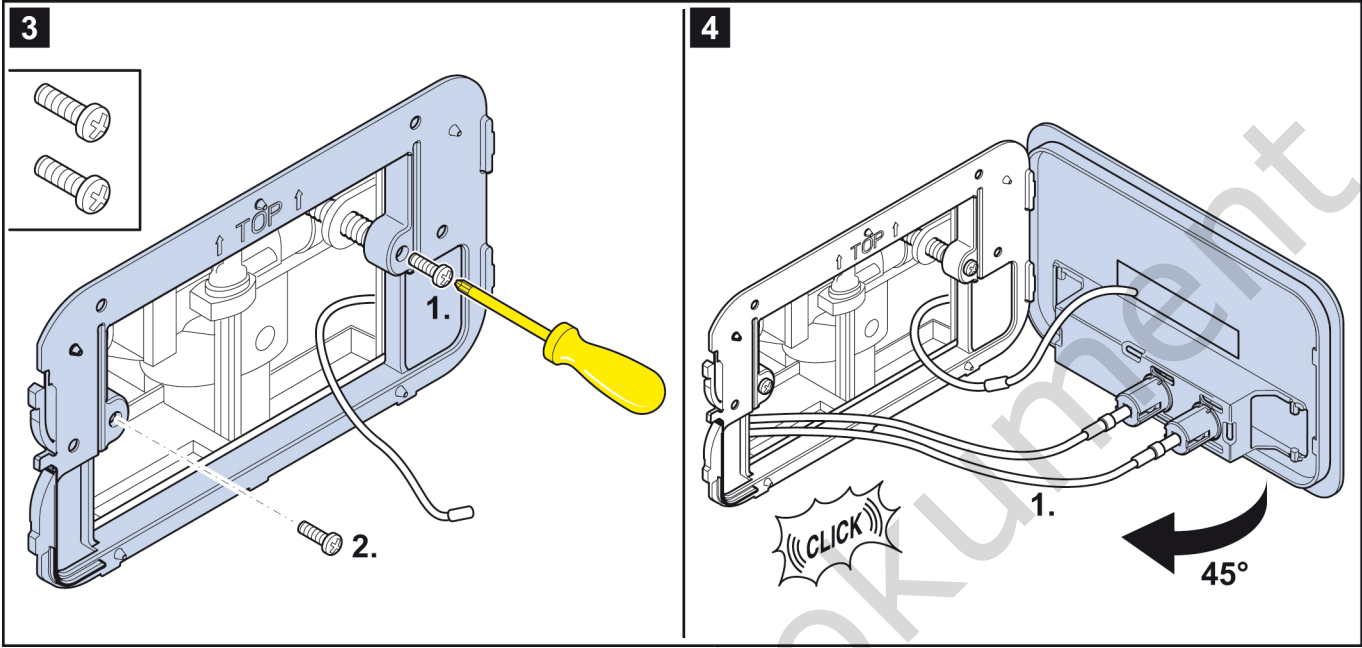

3. Install push plate, see Illustration 5.

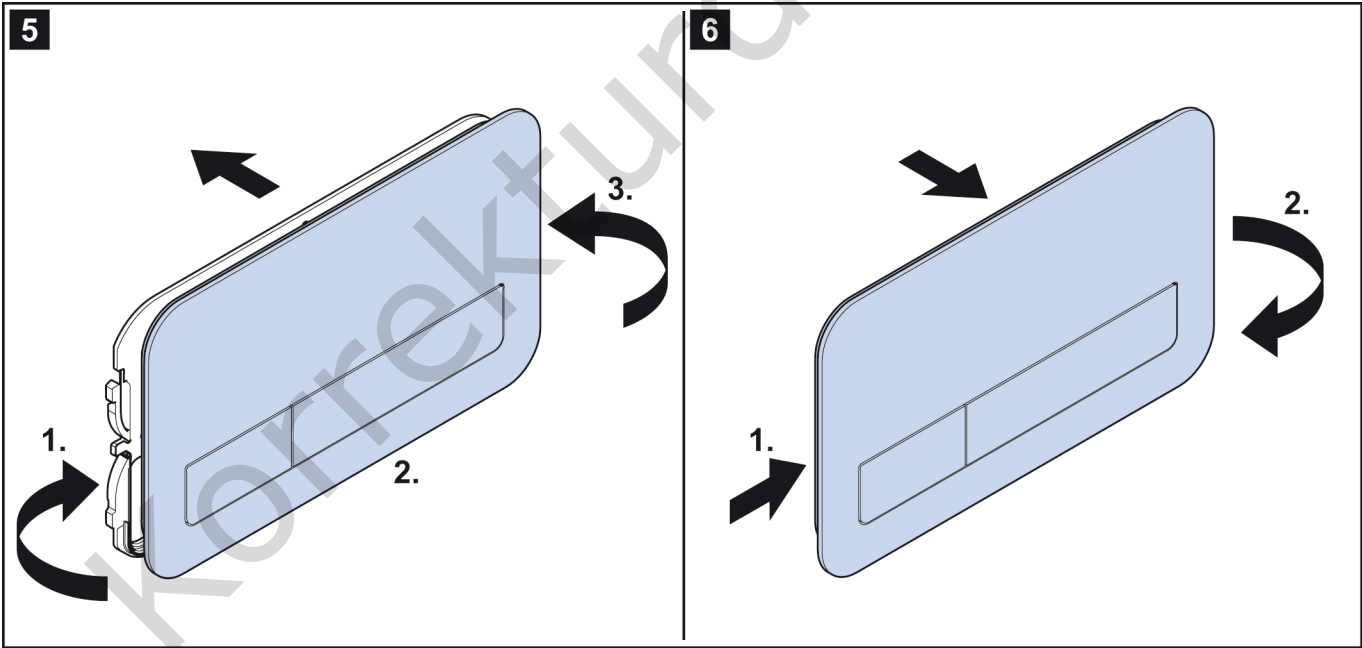

Cleaning

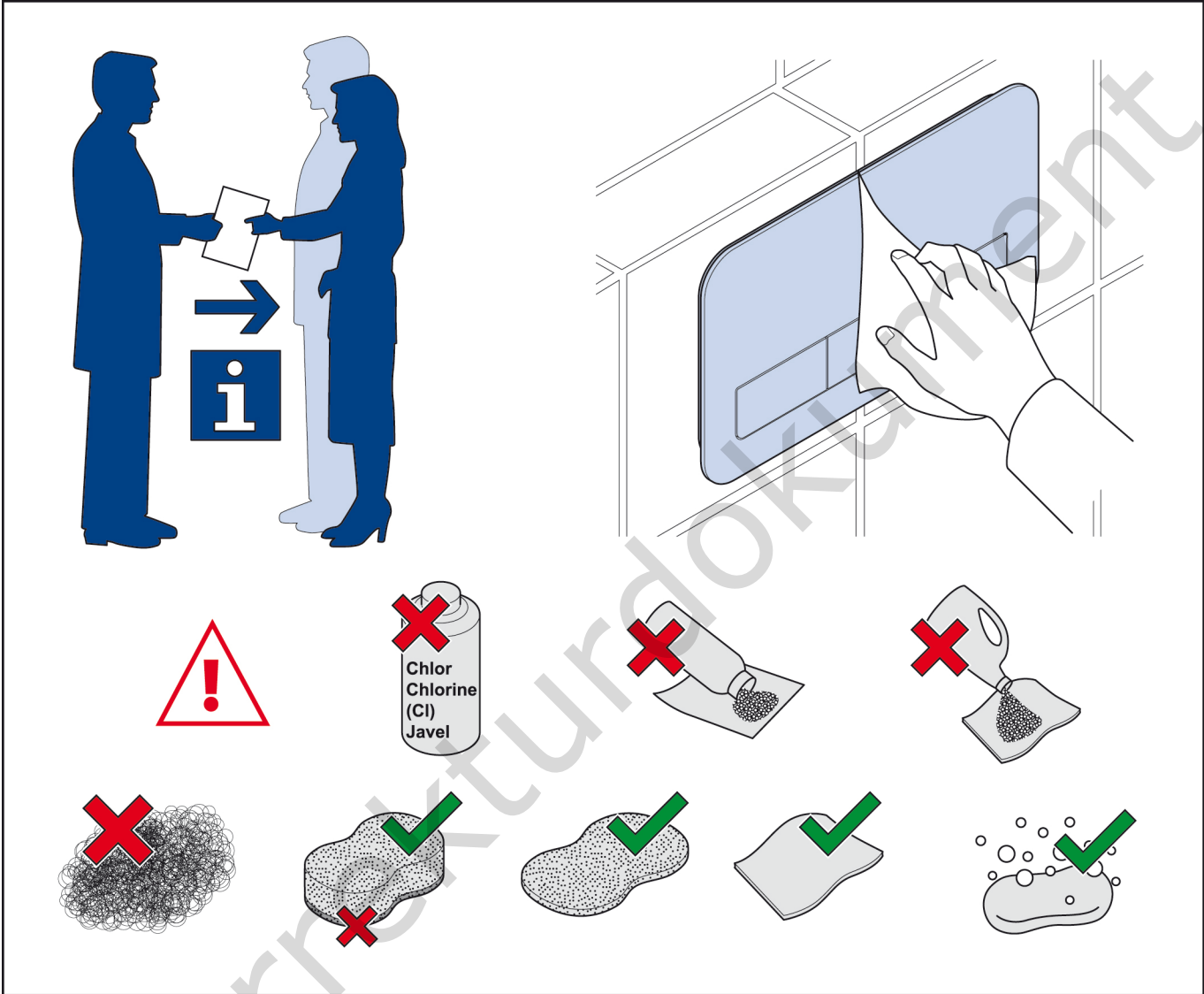

CE

EAC

Seguridad



¡Advertencia!

¡Descarga eléctrica al tocar componentes conductores de corriente!

Se pueden producir lesiones graves e incluso la muerte.

- Únicamente un electricista cualificado debe llevar a cabo la conexión.
- Asegúrese de que la línea está desconectada y asegurada para que no se pueda volver a producir la conexión mientras realiza los trabajos.
- No enchufe ni desenchufe el cable de red con las manos mojadas.

Todos los trabajos en las conexiones eléctricas deben ser realizados por un electricista cualificado de acuerdo con los reglamentos electrotécnicos.

Instalación

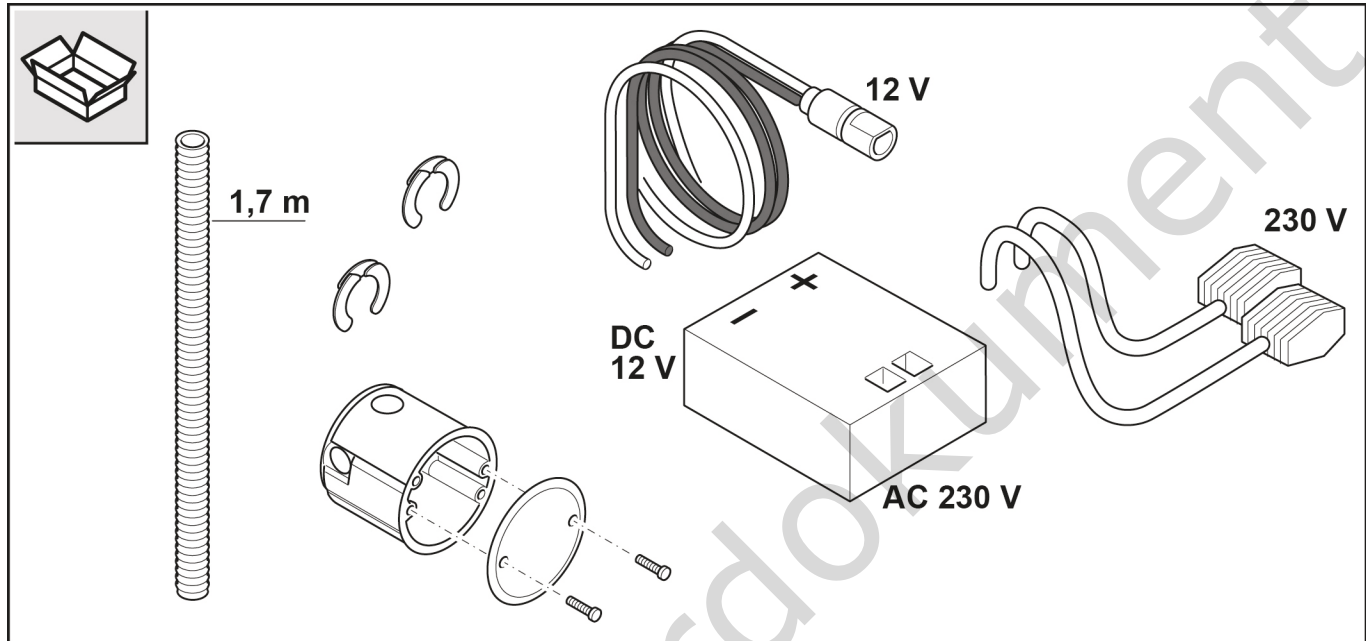

- Determinar el lugar de montaje de la caja empotrada.
 - ⇒ Recomendamos su instalación encima de la cisterna, véase la figura 1.

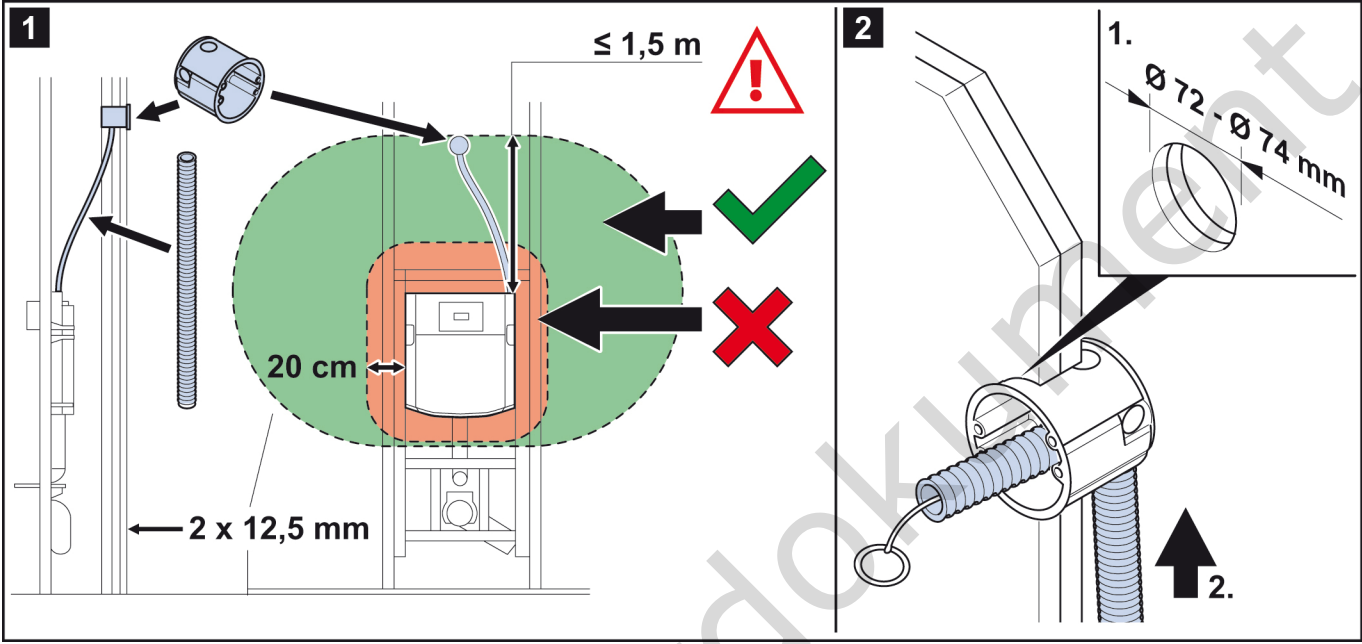

- Montaje de la caja empotrada.
- Tender el tubo de vacío que se suministra con el pulsador desde la caja empotrada hasta la cisterna, véase la figura 2.

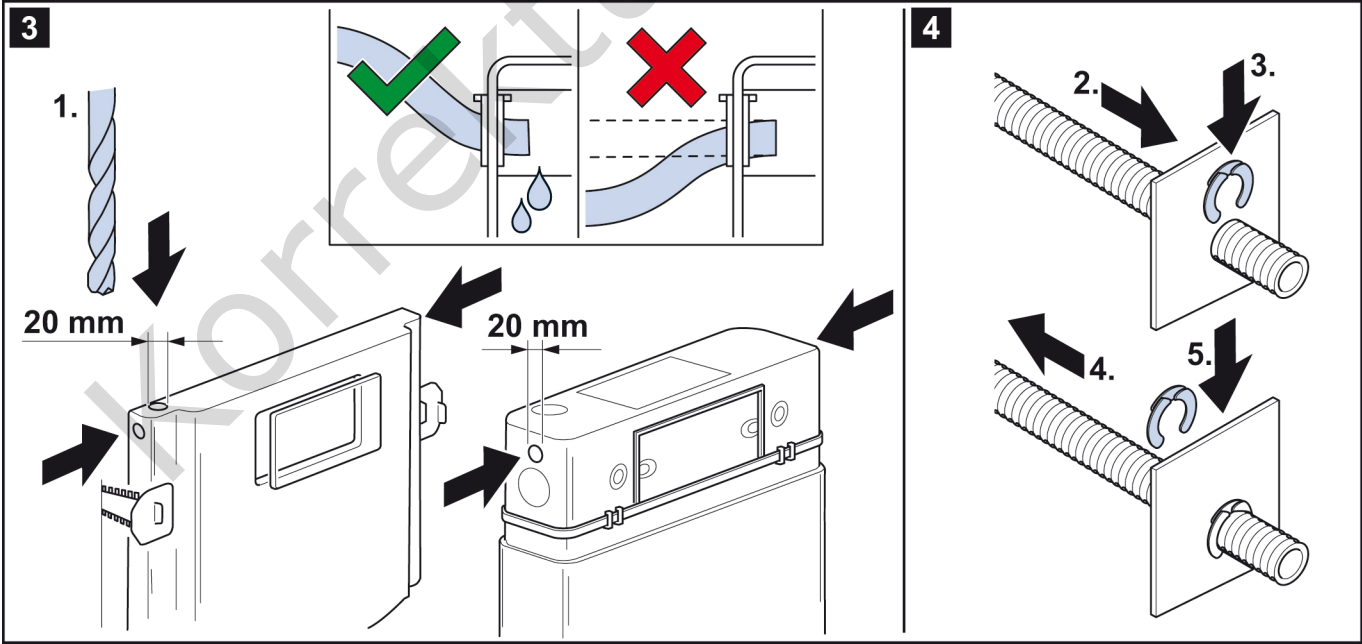

Montaje del pulsador

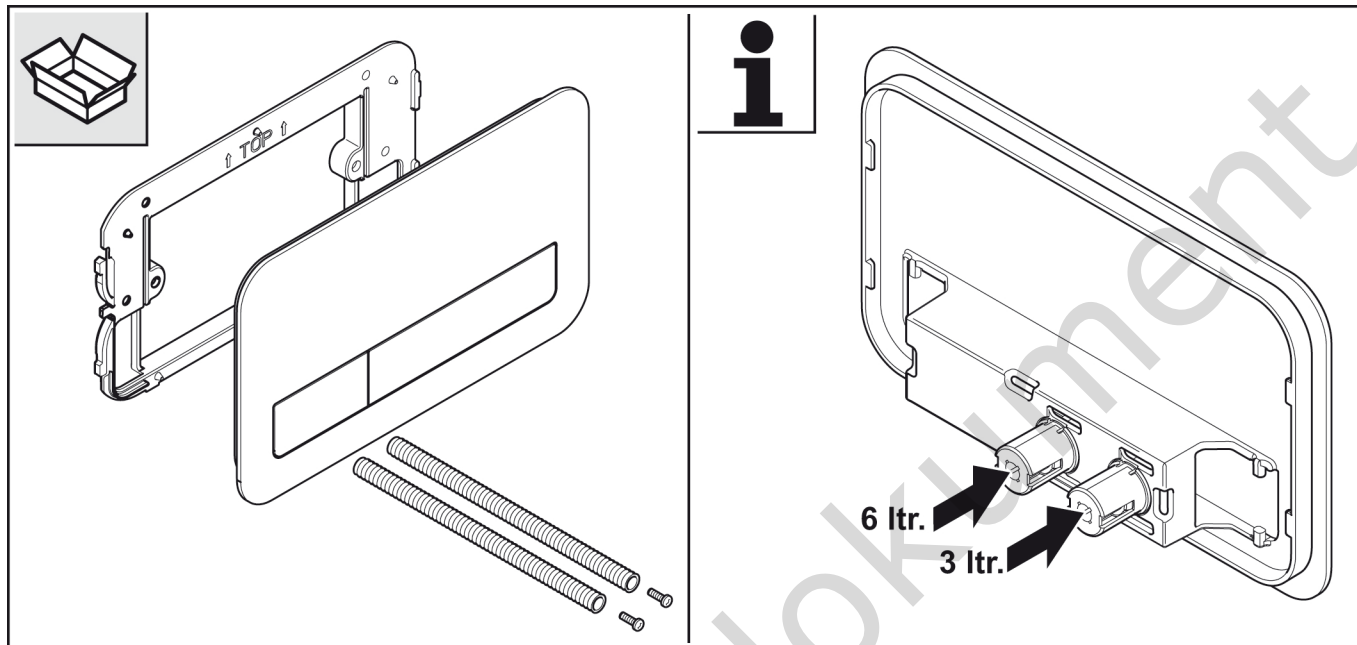

1. Atornillar la placa de soporte.

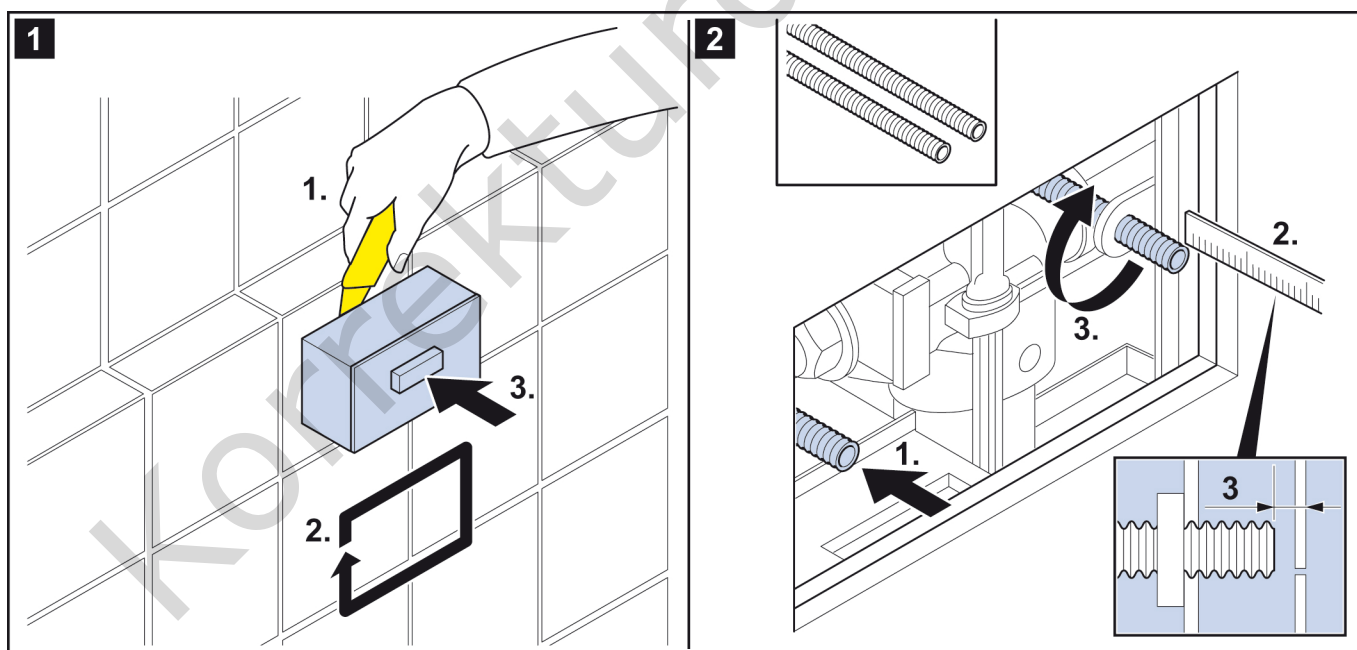

2. Conectar los cables a la toma, véanse las figuras 3 y 4.

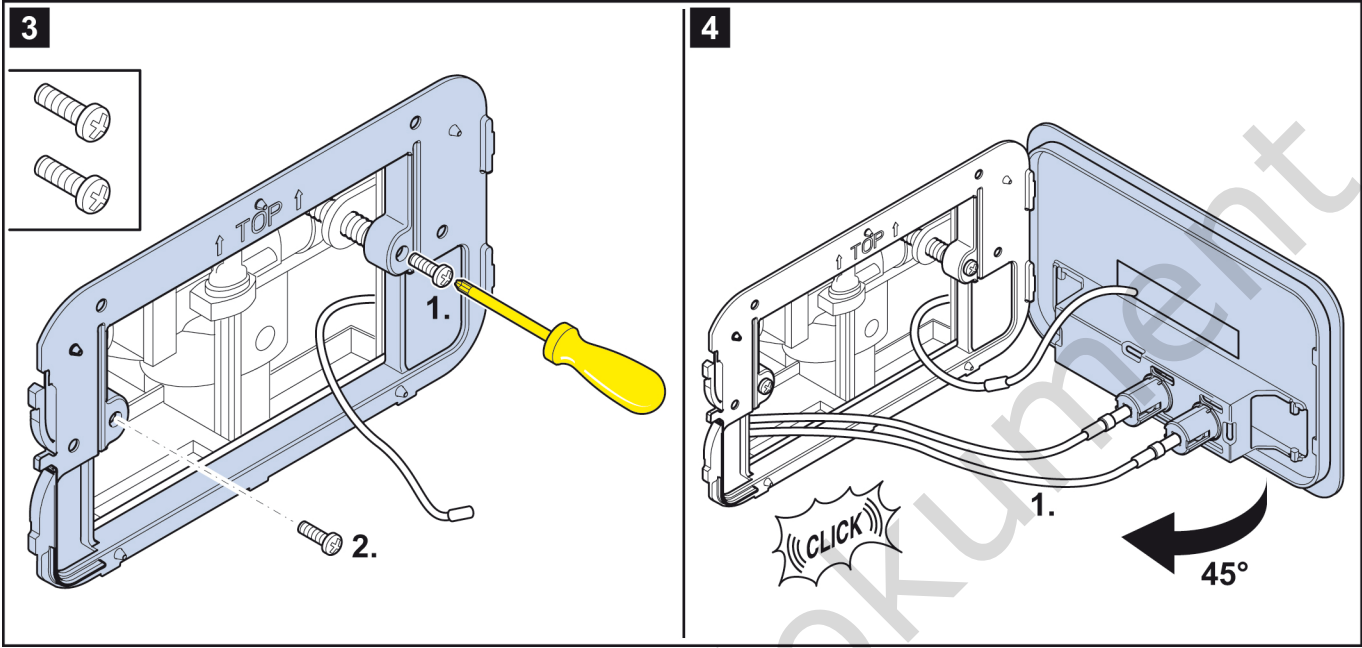

3. Montar el pulsador, véase la figura 5.

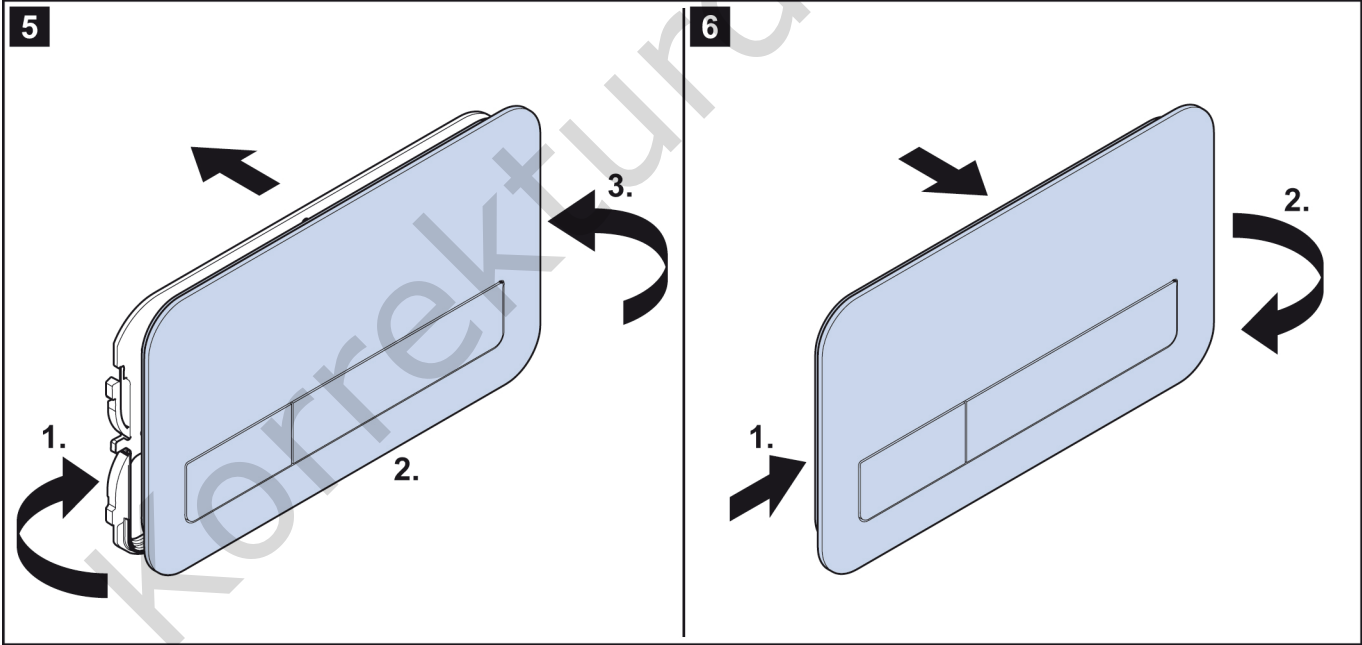

Limpeza

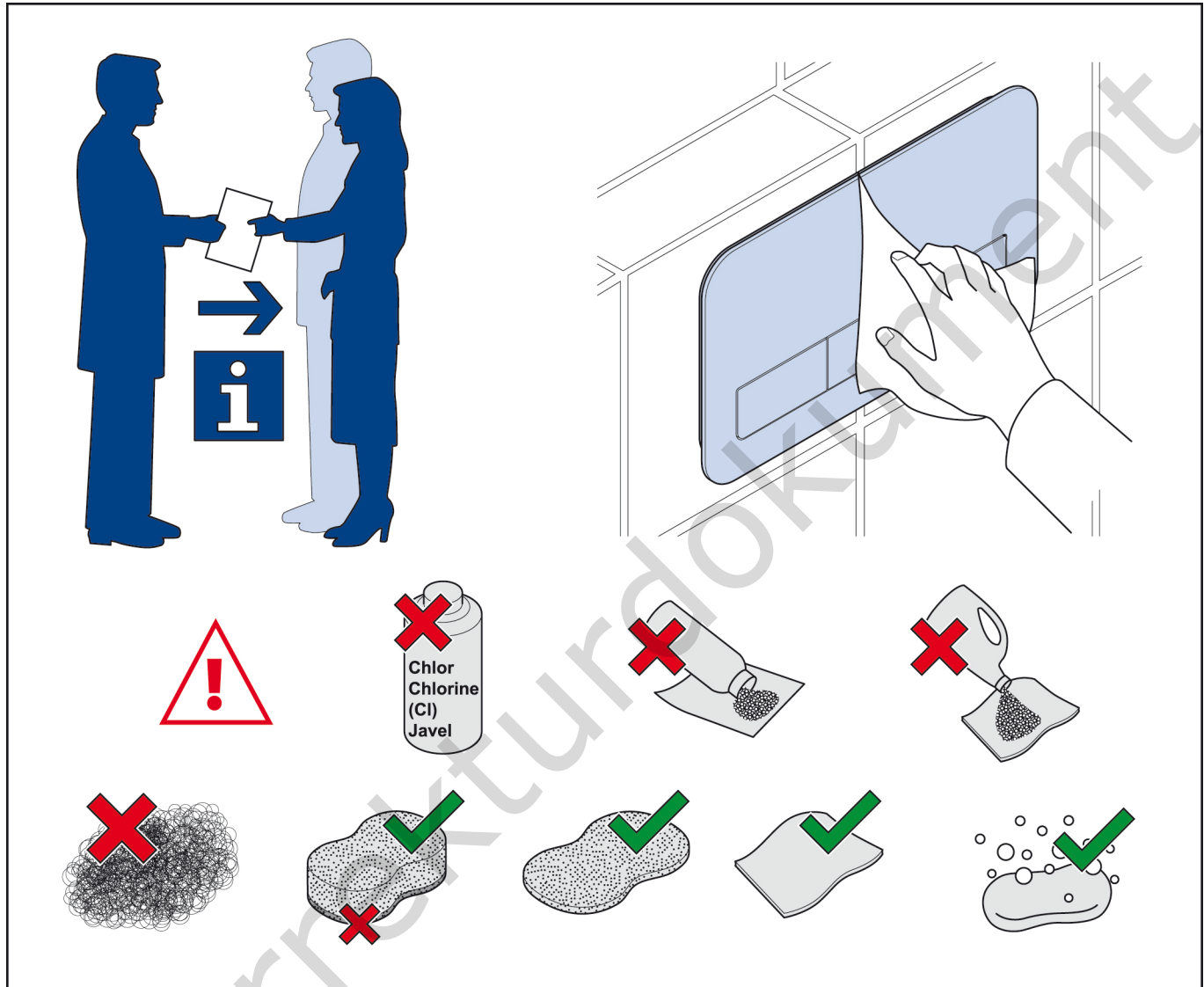

CE

EAC

Sécurité



Avertissement !

Attention aux risques d'électrocution en cas de contact avec les composants sous tension !

Cela peut engendrer des blessures graves, voire mortelles.

- Laisser impérativement un électricien procéder au raccordement au secteur.
- Vérifier avant de commencer à travailler que le câble n'est plus sous tension et qu'une remise sous tension n'est pas possible.
- Ne pas brancher ou débrancher la prise de courant les mains mouillées.

L'ensemble des travaux de raccordement électrique doit être réalisé impérativement par un spécialiste dans le respect de la réglementation concernant les installations électriques.

Installation

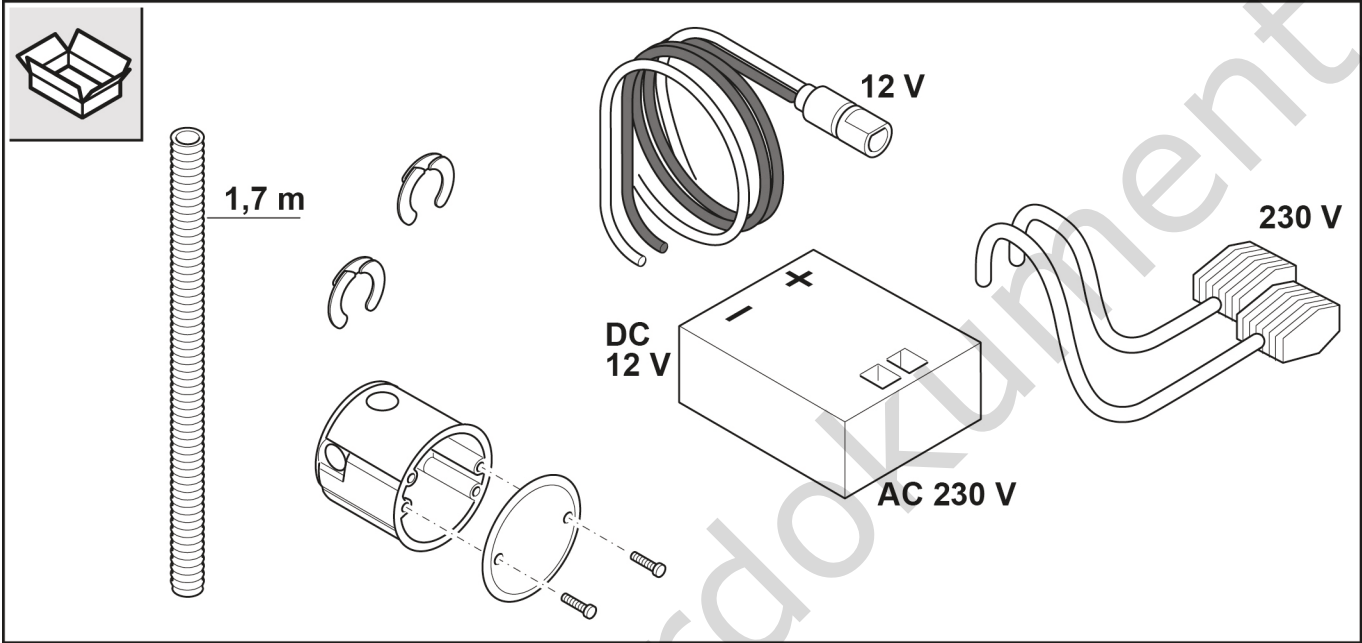

- Détermination de l'emplacement de montage de la prise encastrée.
⇒ Notre recommandation : au-dessus de la chasse d'eau, voir schéma 1.

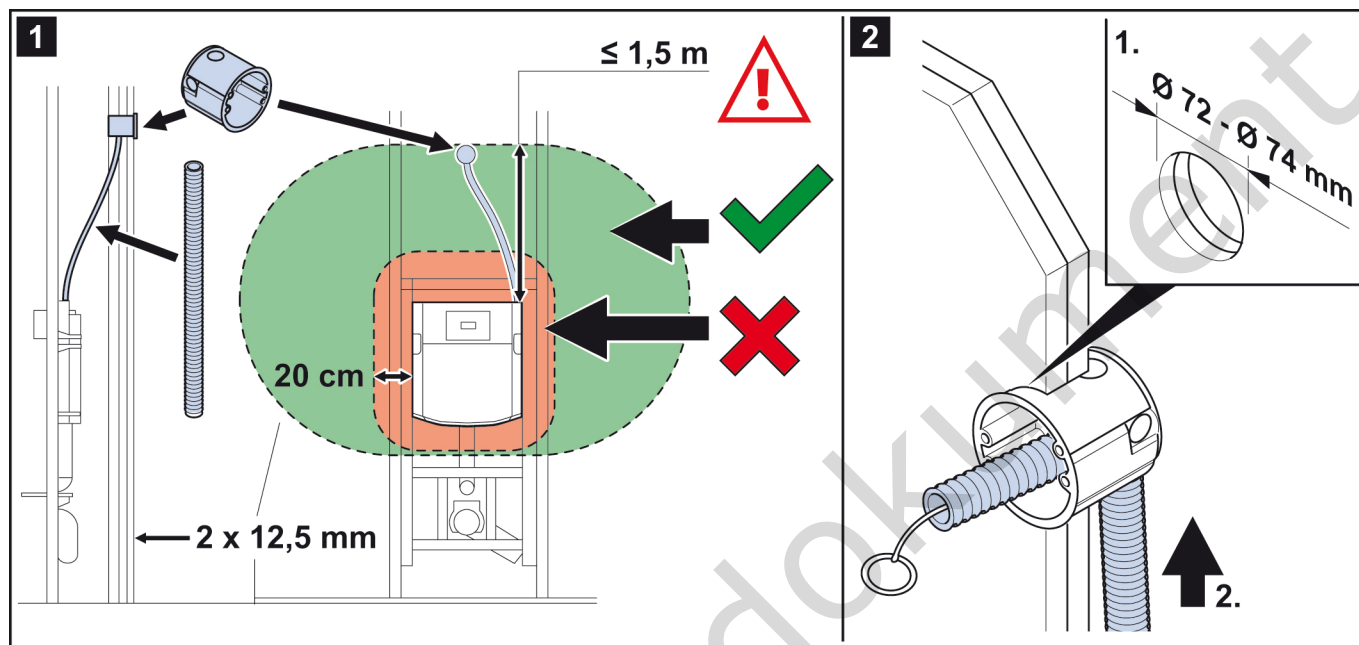

- Montage de la prise encastrée.
- Poser la gaine de la prise encastrée jusqu'à la chasse d'eau, voir schéma 2.

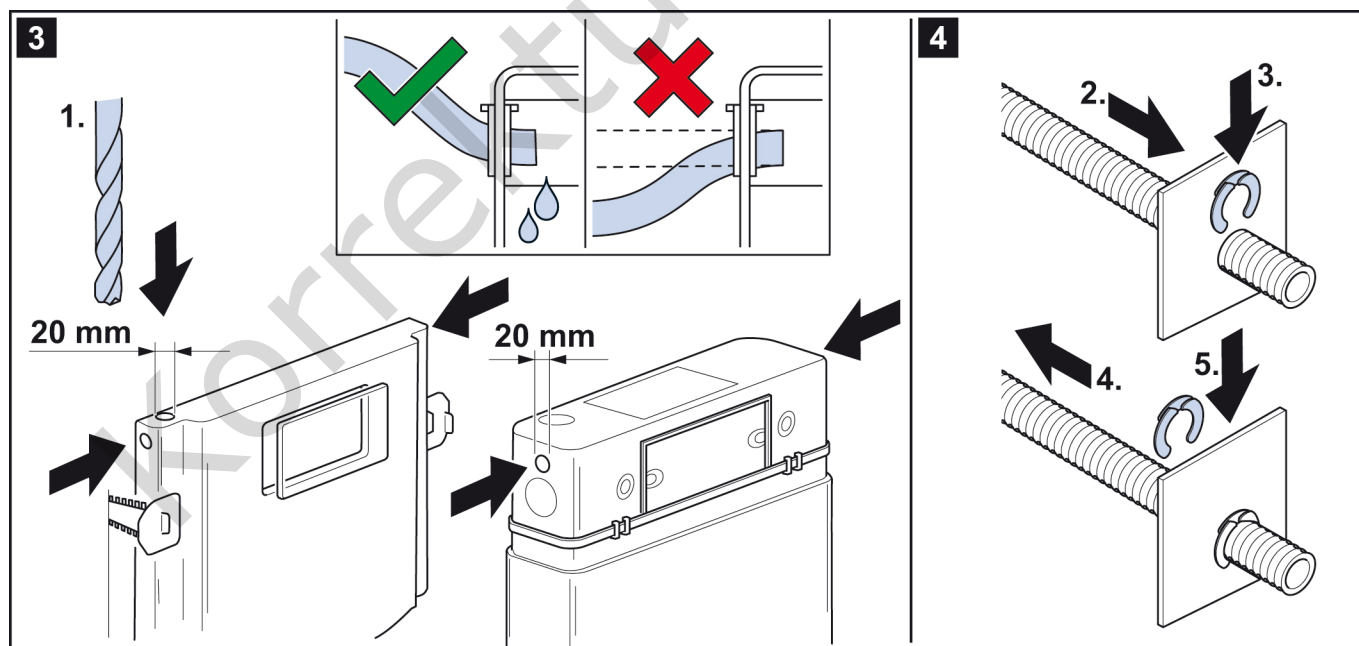

Montage de la plaque de déclenchement

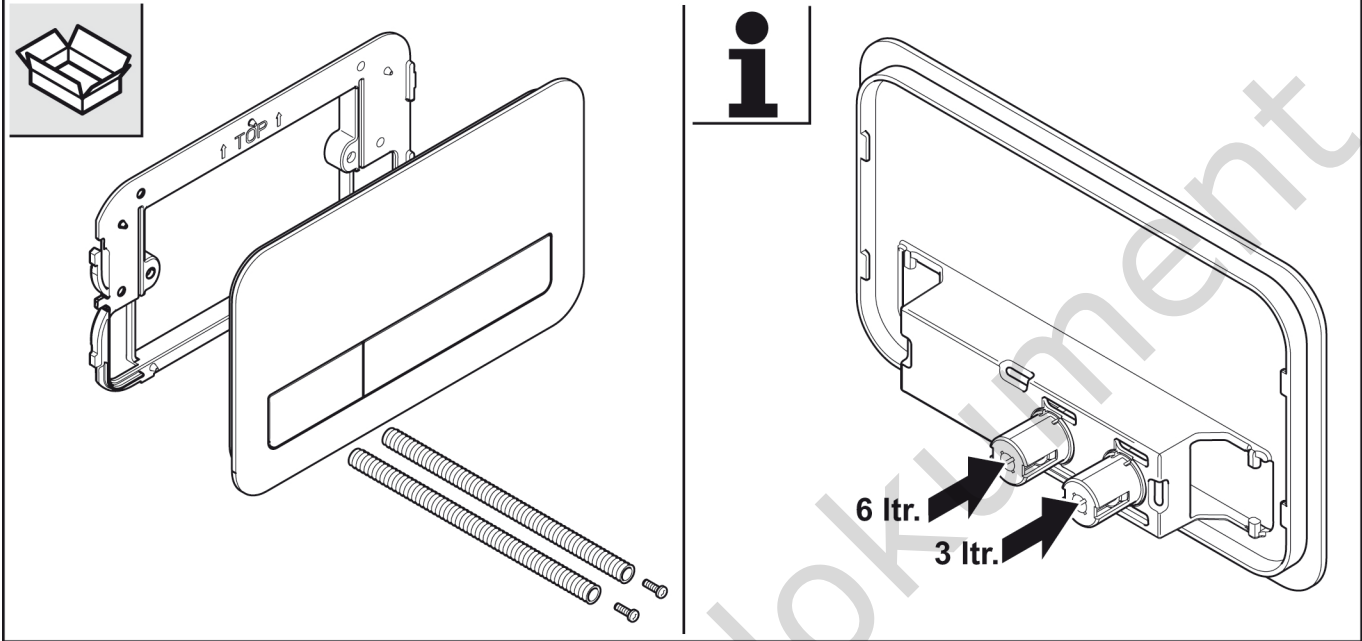

1. Fixer la plaque support avec les vis.

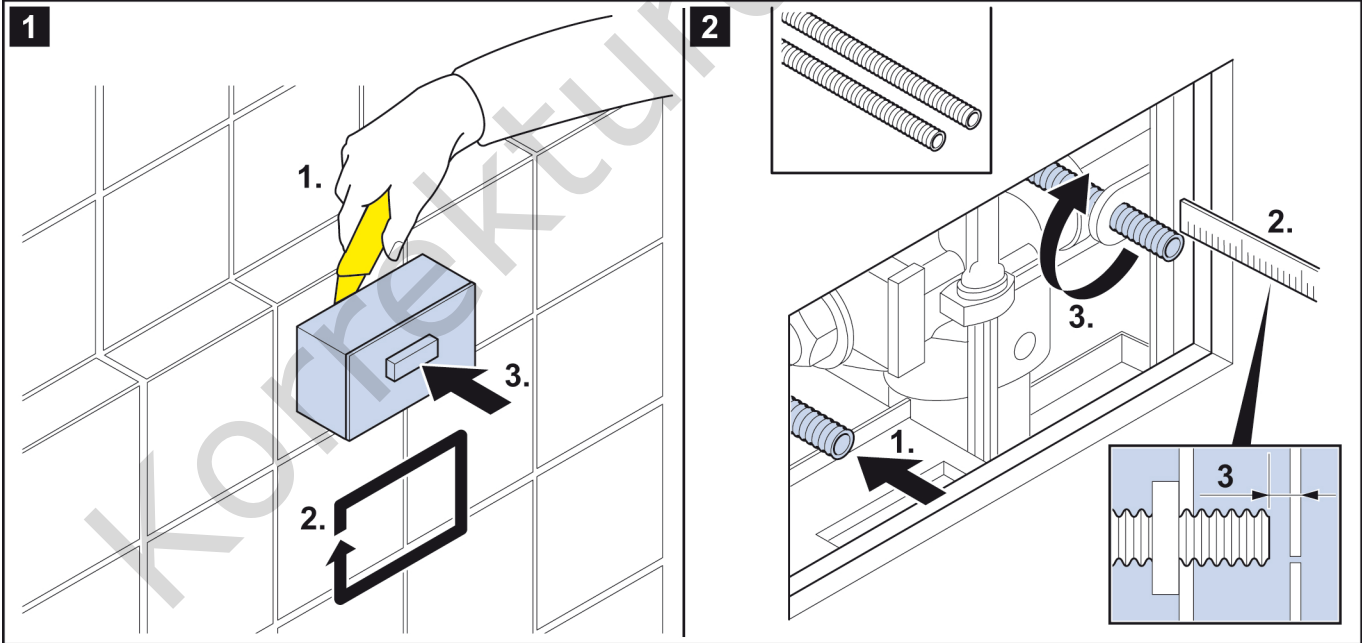

2. Brancher la fiche à la prise, voir schémas 3 et 4.

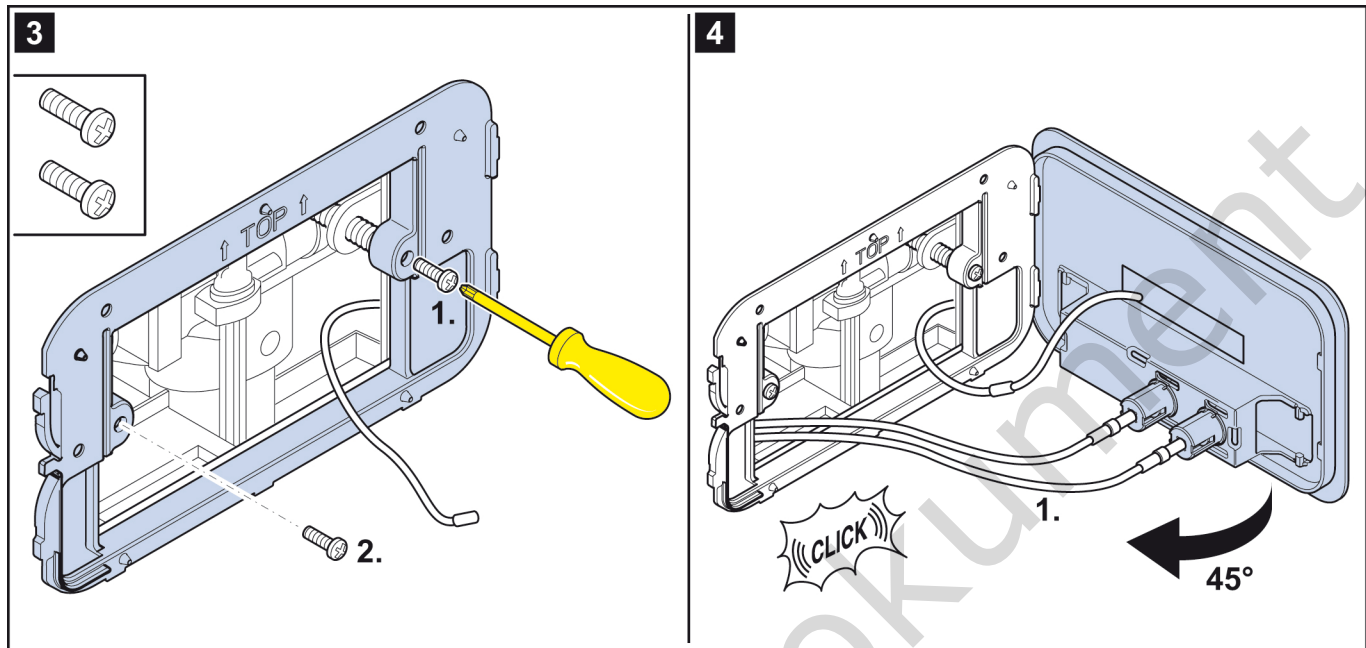

3. Monter la plaque de déclenchement, voir schéma 5.

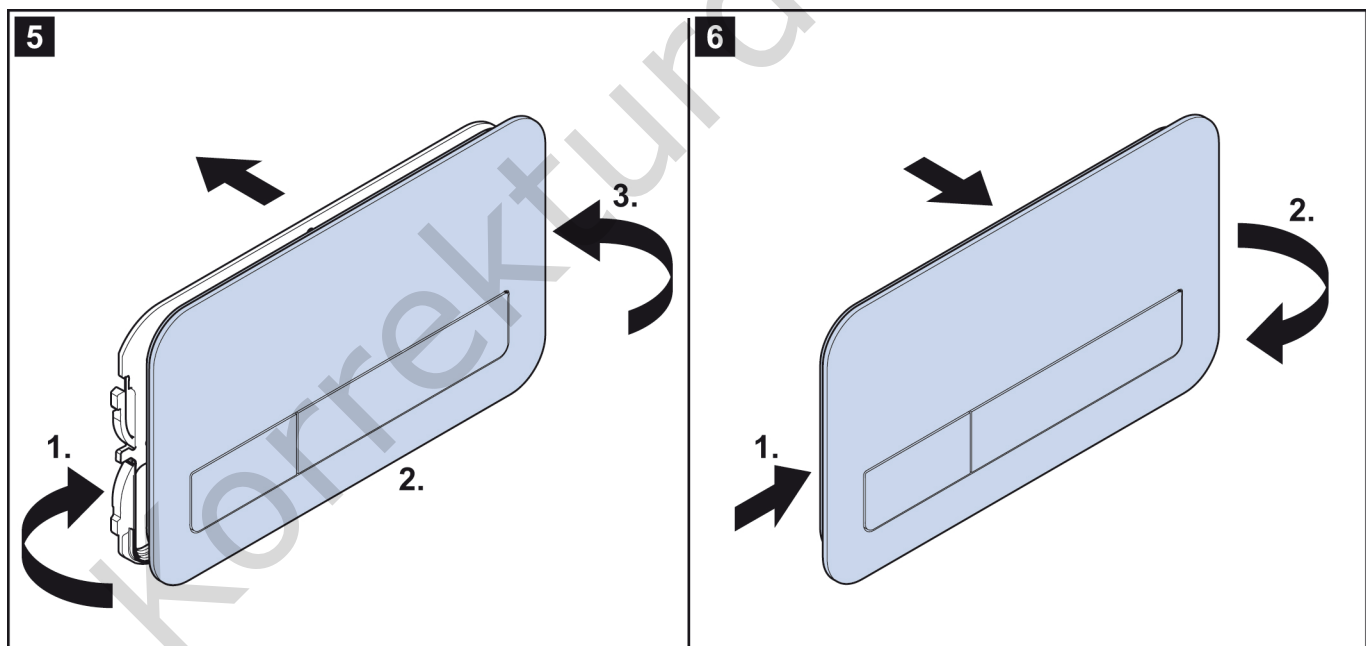

Nettoyage

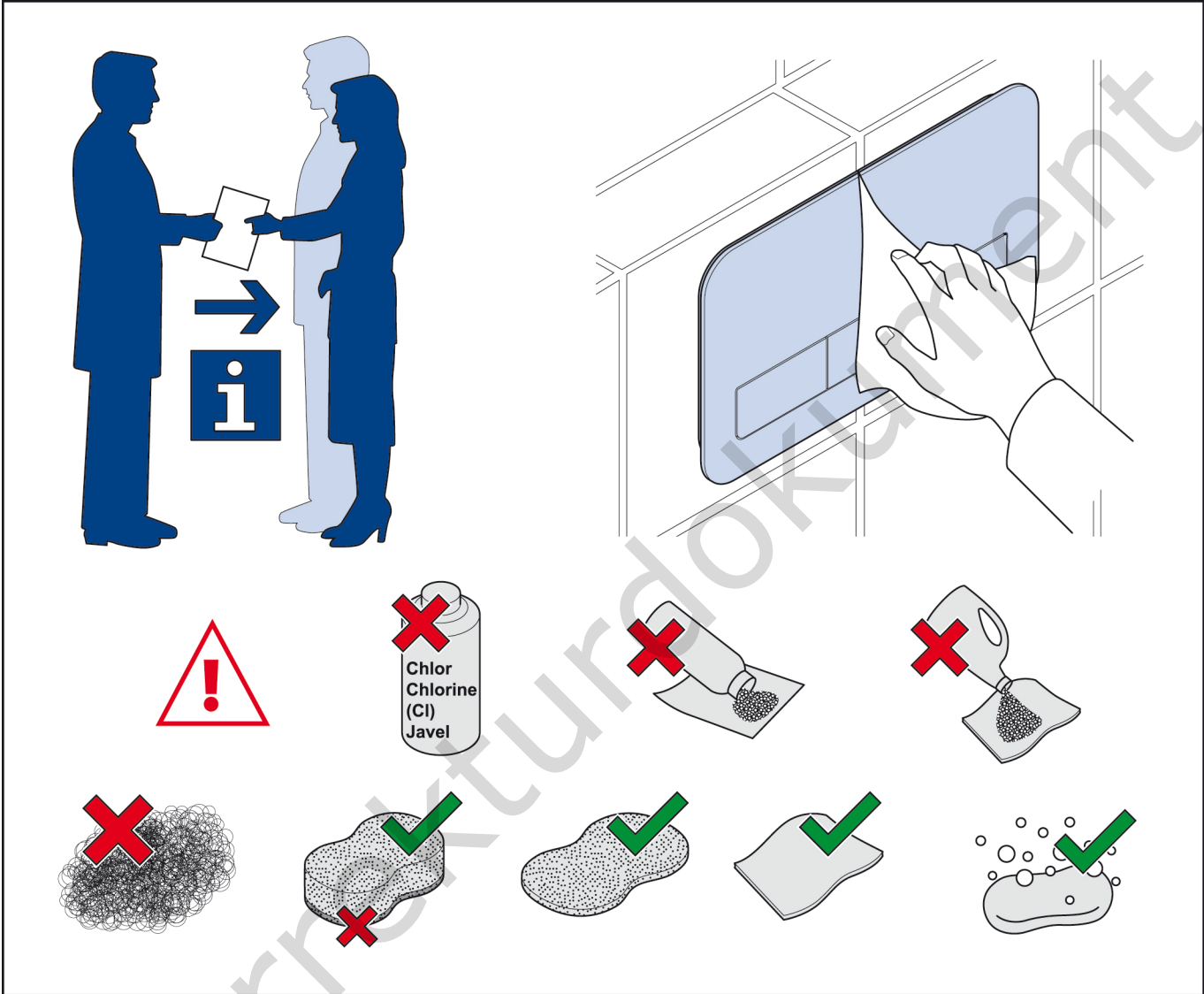

CE

EAC

Veiligheid



Waarschuwing!

Elektrische schok door aanraking van stroomvoerende onderdelen!

Ernstig letsel en zelfs de dood kunnen het gevolg zijn.

- De netaansluiting uitsluitend door een elektricien laten uitvoeren.
- Ervoor zorgen dat tijdens de werkzaamheden de leiding niet onder stroom staat en beveiligd is tegen opnieuw inschakelen.
- De netstekker niet met natte handen inpluggen of verwijderen.

Alle werkzaamheden aan elektrische aansluitingen mogen uitsluitend door een elektricien volgens de elektrotechnische voorschriften worden uitgevoerd.

Installatie

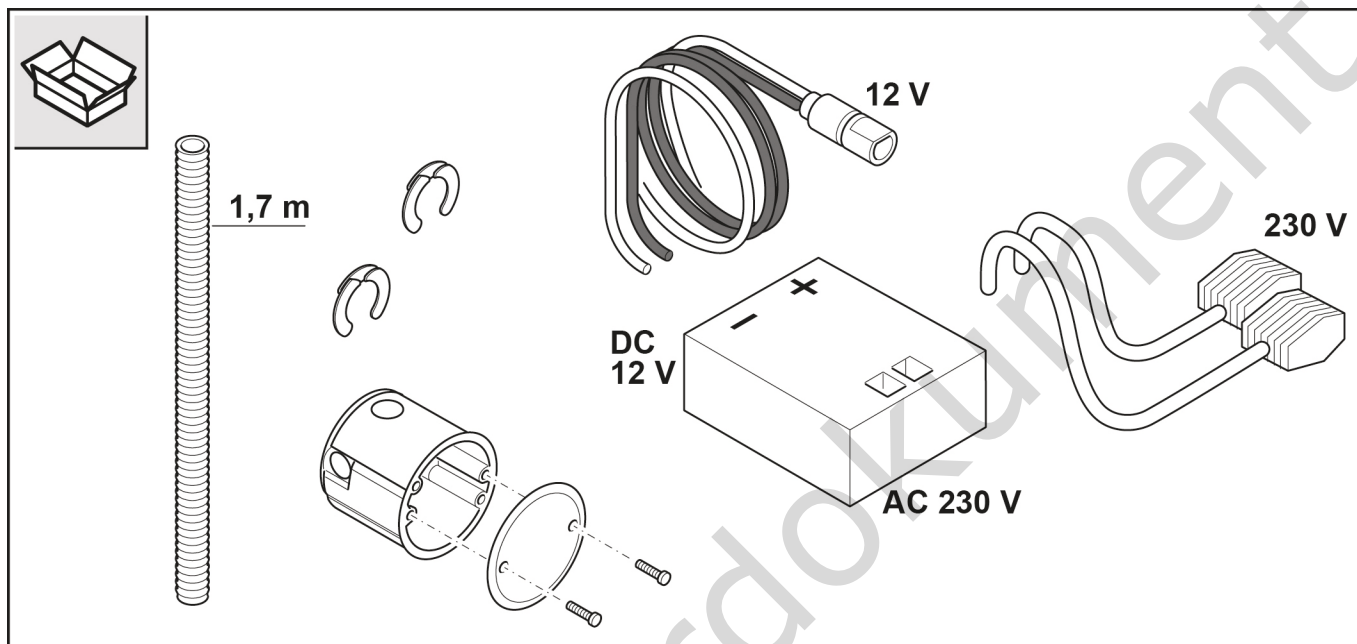

1. De montageplaats van de inbouwdoos bepalen.
 ⇒ Ons advies, boven de spoelbak, zie afbeelding 1.

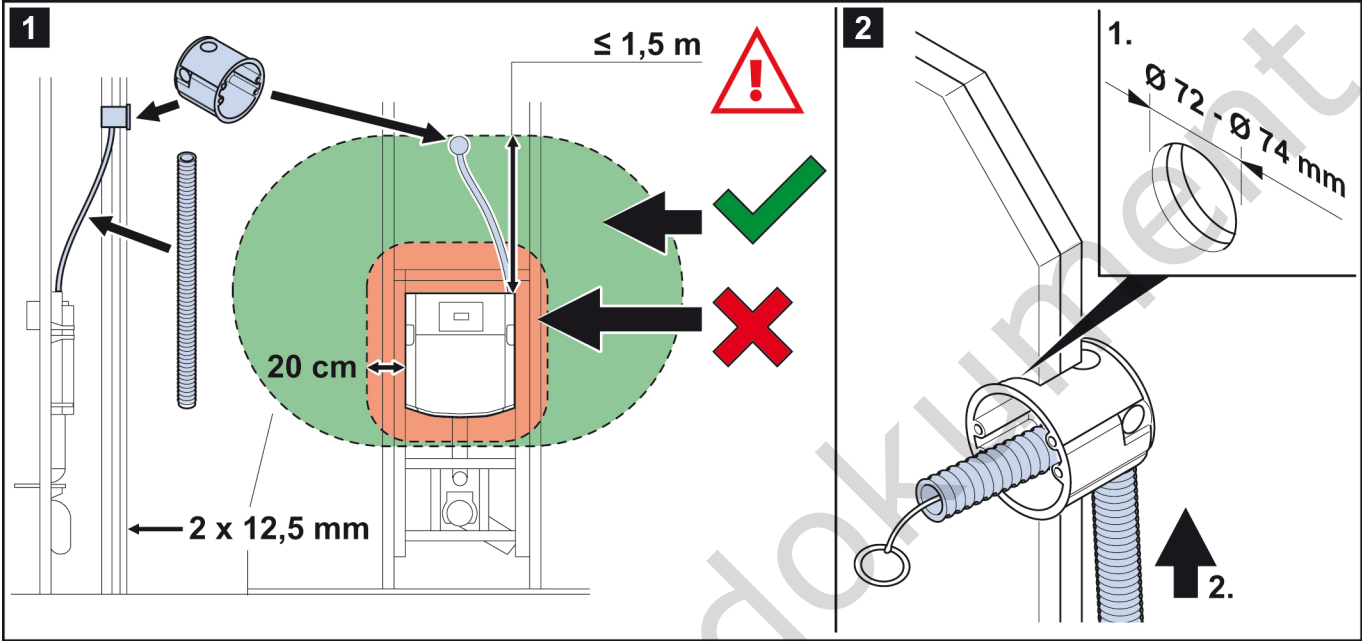

2. De inbouwdoos monteren.
3. Monteer bijgevoegde lege buis van de inbouwdoos naar de spoelbak, zie afbeelding 2.

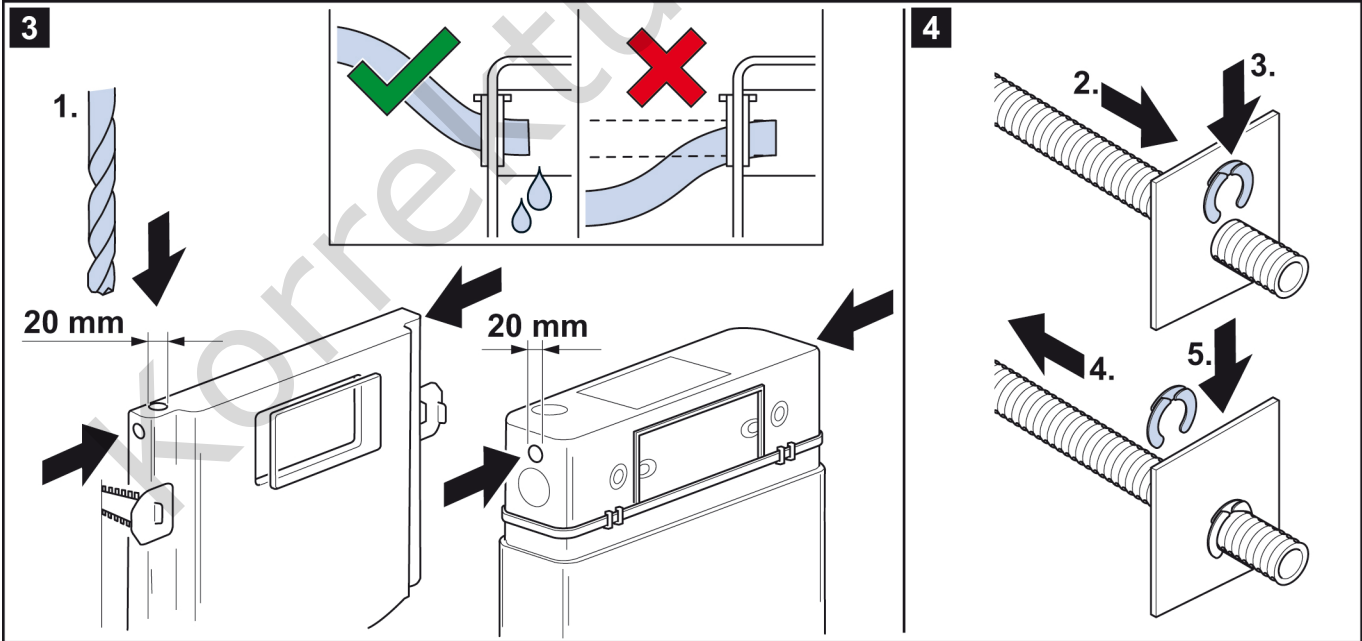

Drukplaat monteren

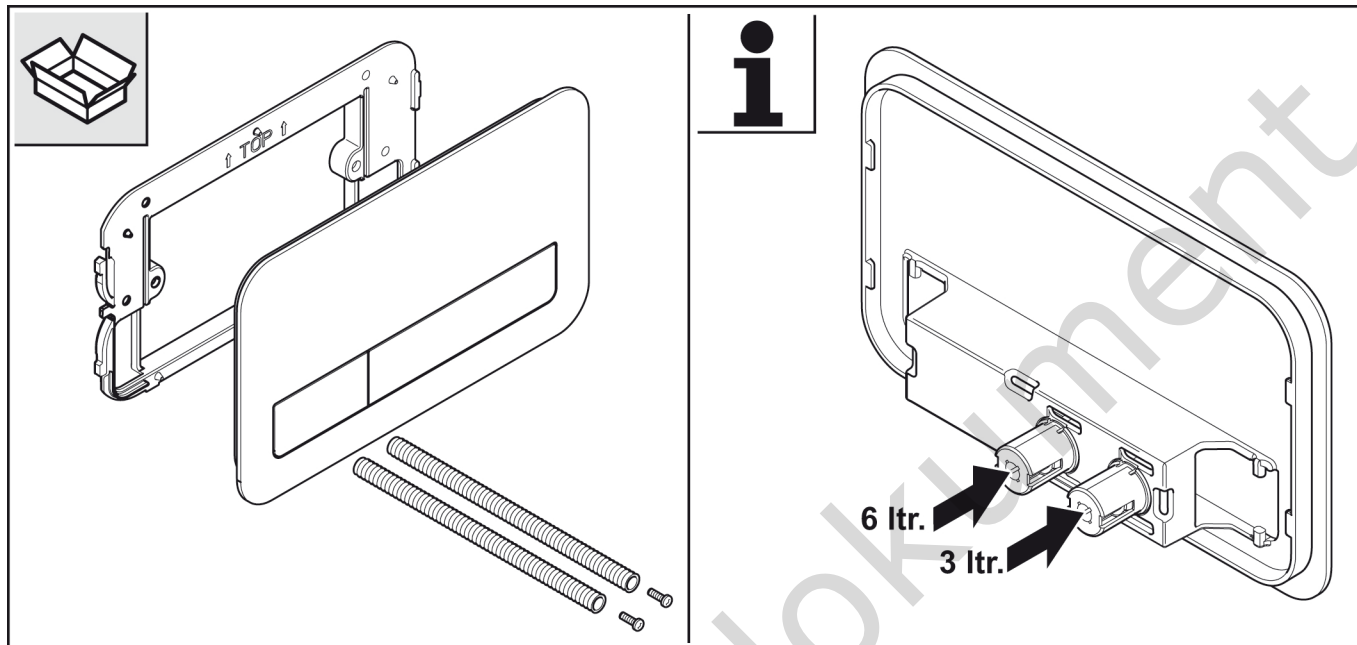

1. Draagplaat vastschroeven.

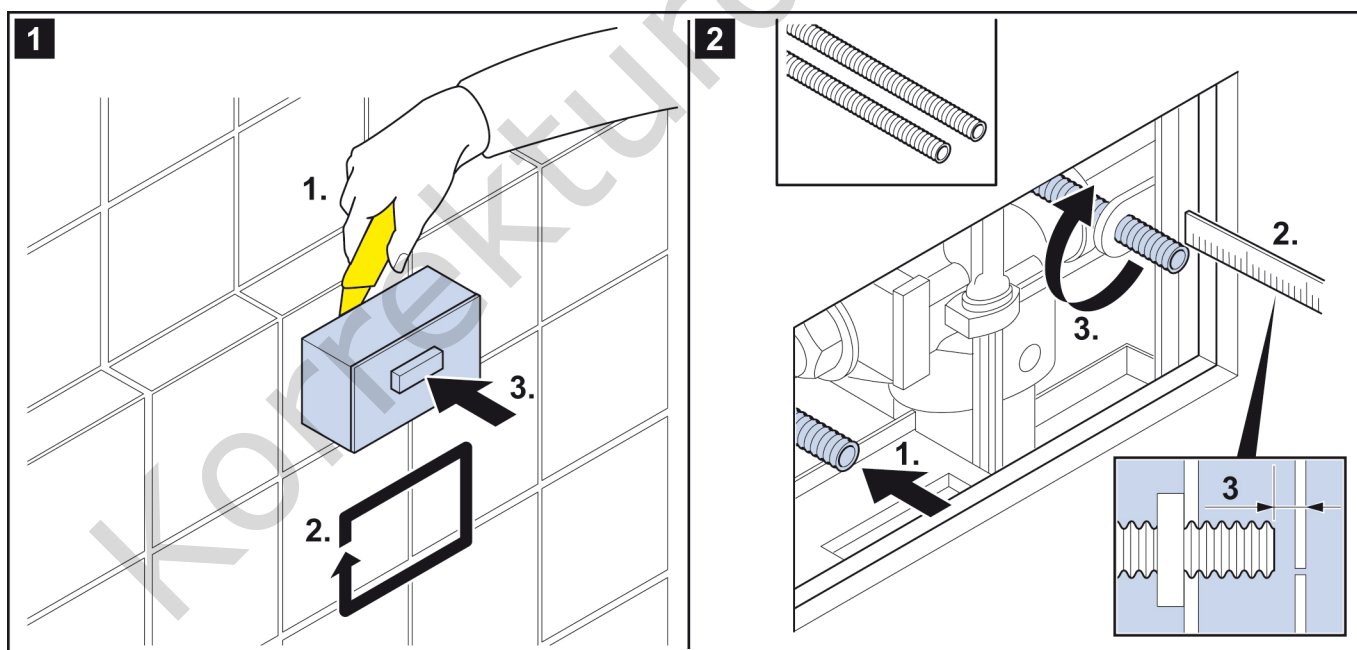

2. Stekker op contrastekker aansluiten, zie afbeelding 3 en 4.

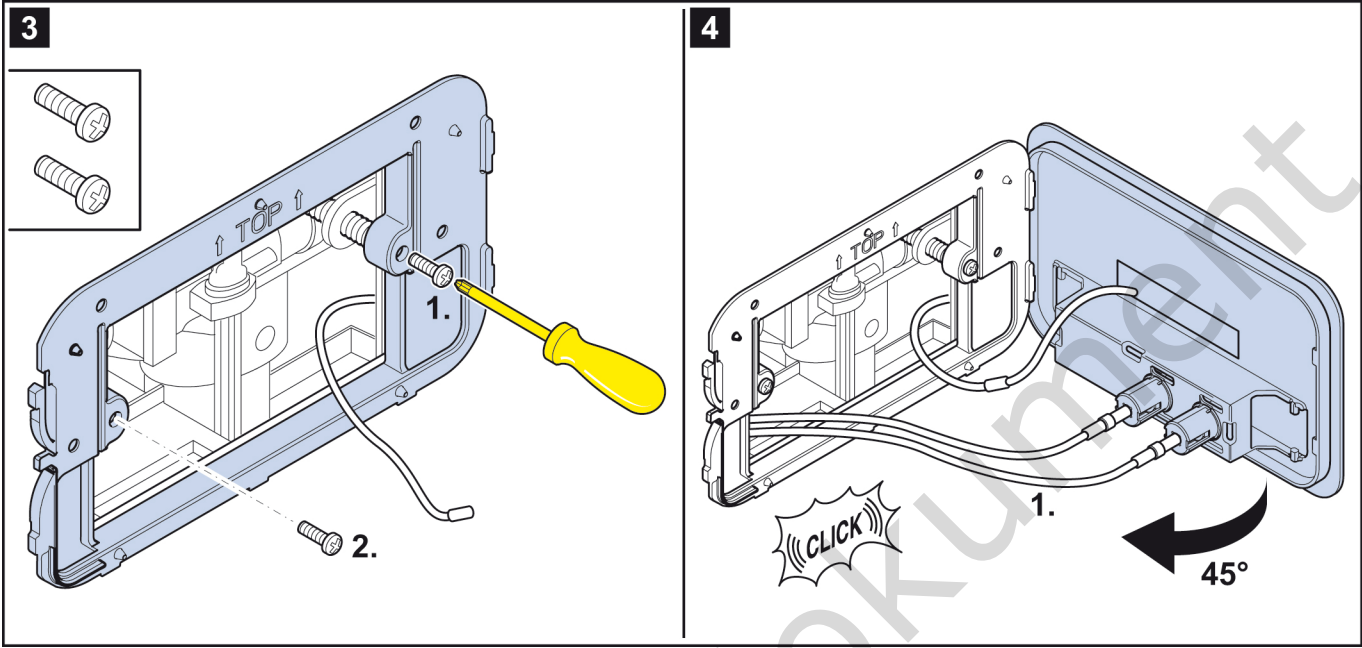

3. Drukplaat monteren, zie afbeelding 5.

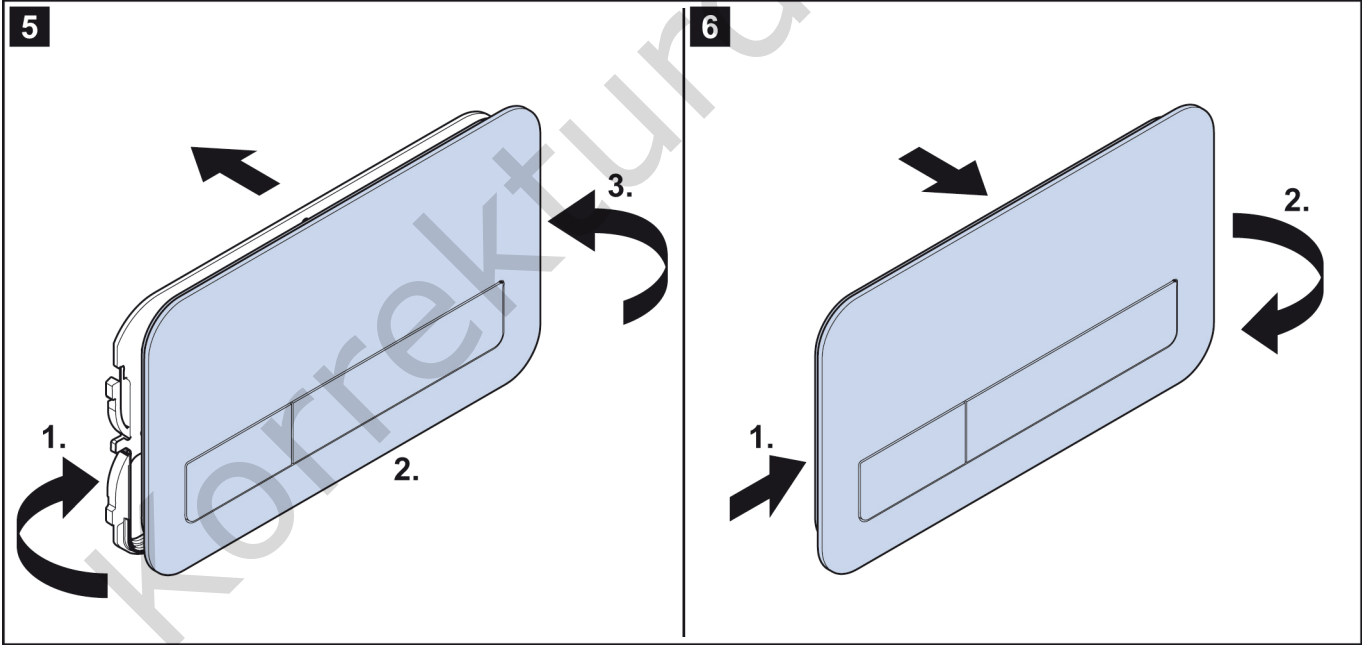

Reiniging

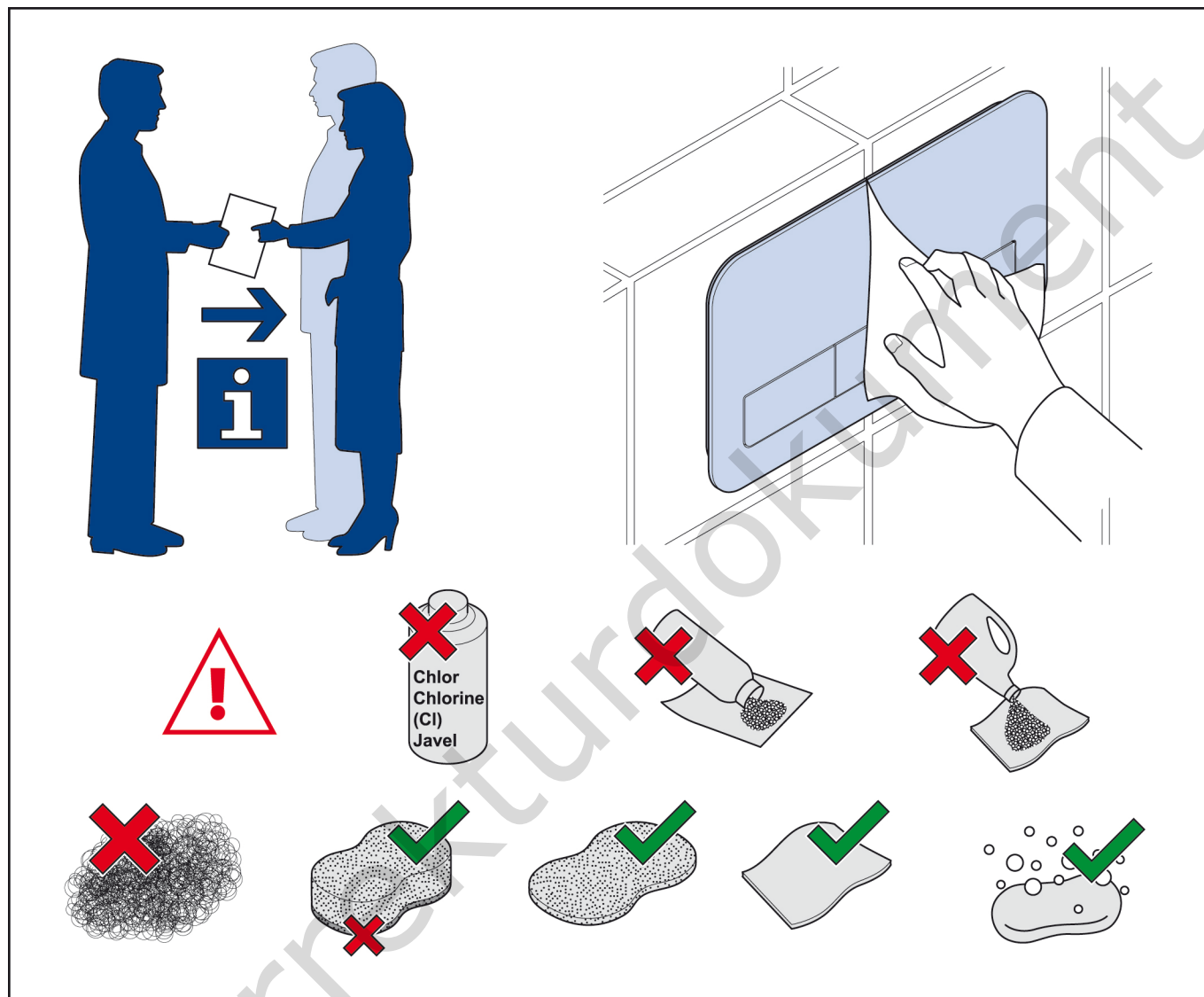

CE

EAC

Sicurezza



Attenzione!

Pericolo di scossa elettrica da contatto con componenti sotto tensione!

La conseguenza possono essere lesioni gravi o anche fatali.

- Far eseguire il collegamento alla rete esclusivamente da elettrotecnici.
- Assicurarsi che durante i lavori la linea elettrica sia fuori tensione e protetta da eventuali riattivazioni.
- Non inserire o staccare la spina di rete a mani bagnate.

Tutti gli interventi ai collegamenti elettrici possono essere eseguiti soltanto da personale elettrotecnico specializzato conformemente alle regole elettrotecniche.

Installazione

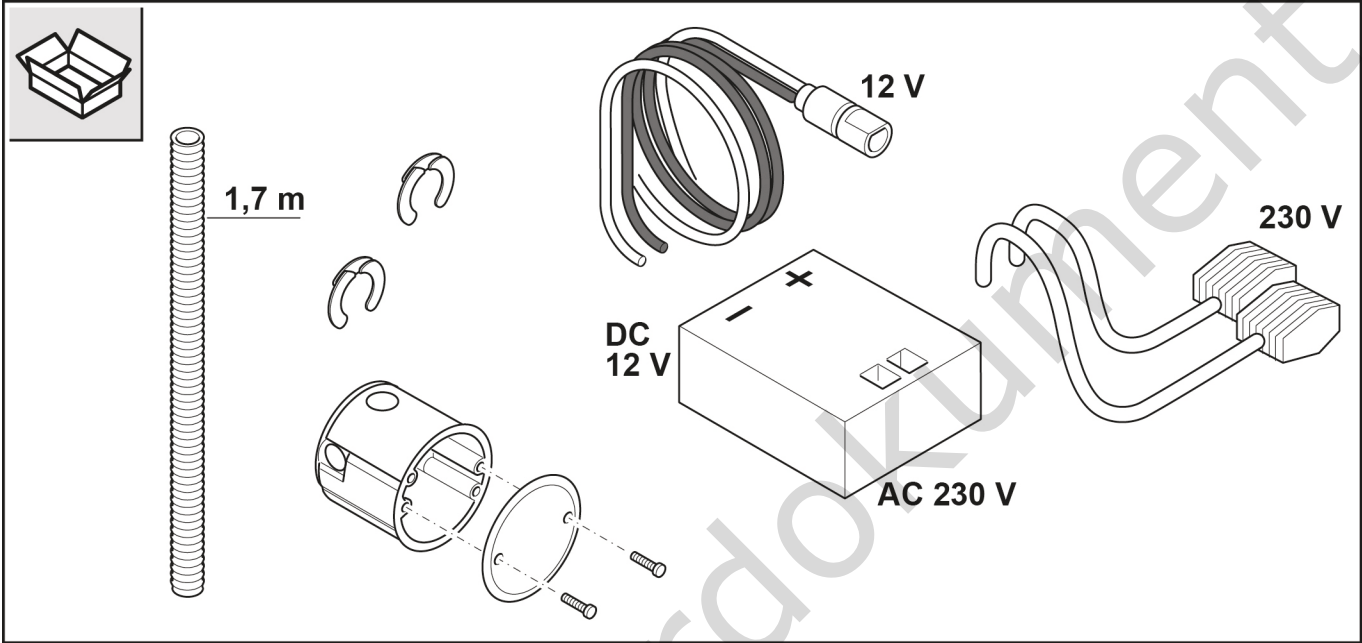

IT

1. Determinare la sede di montaggio della scatola sotto intonaco.
⇒ Si consiglia di effettuare il montaggio sopra la cassetta di risciacquo, vedi fig. 1.

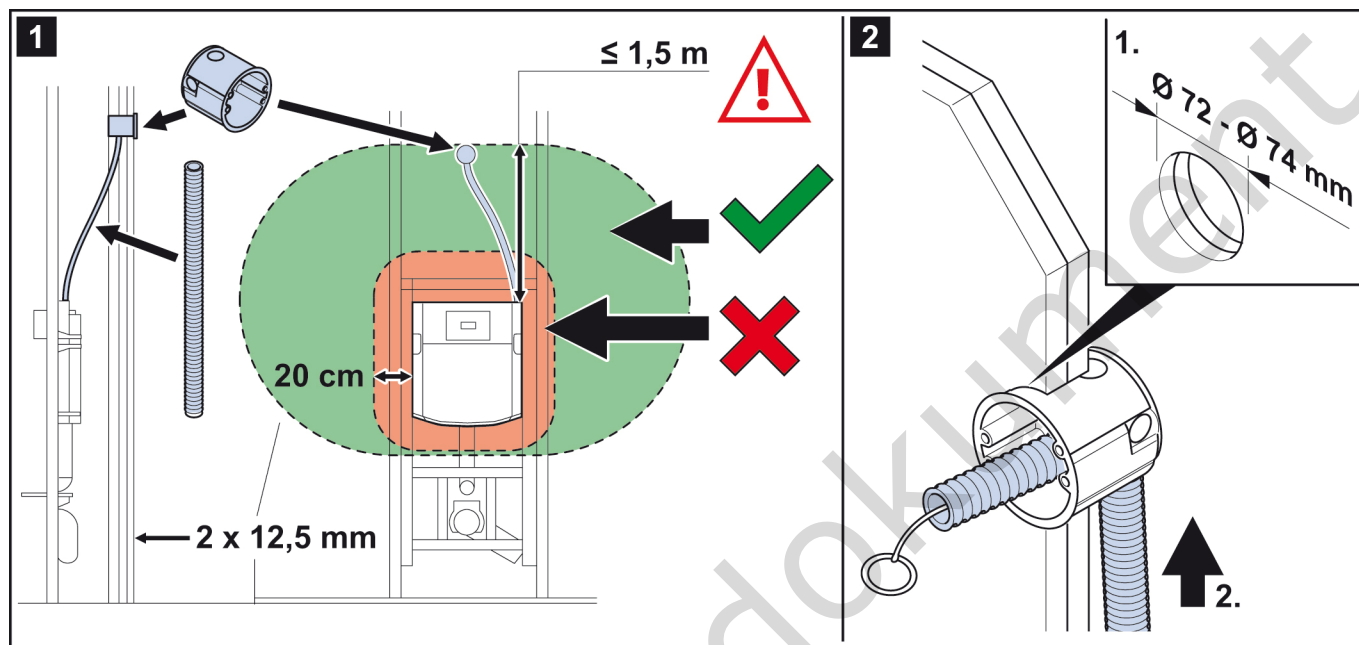

2. Montare la scatola sotto intonaco.
3. Posare la canalina in dotazione dalla scatola sotto intonaco alla cassetta di risciacquo, vedi fig. 2.

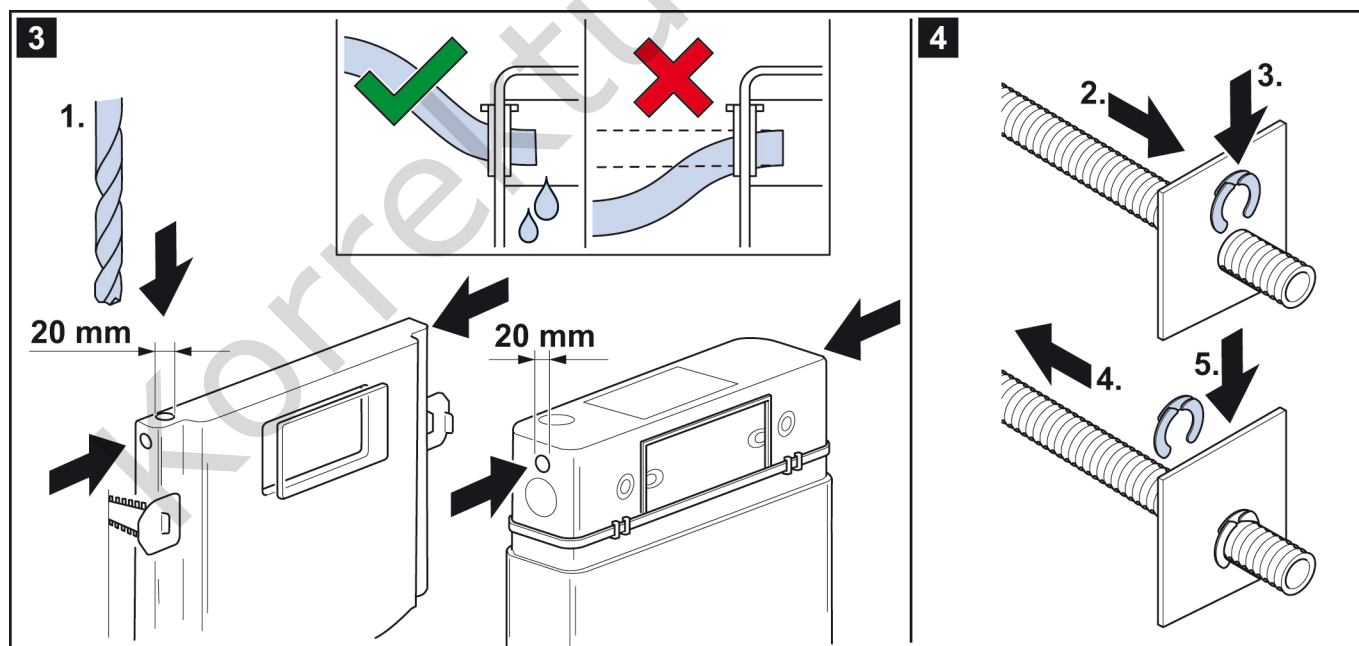

Montaggio della piastra a pressione

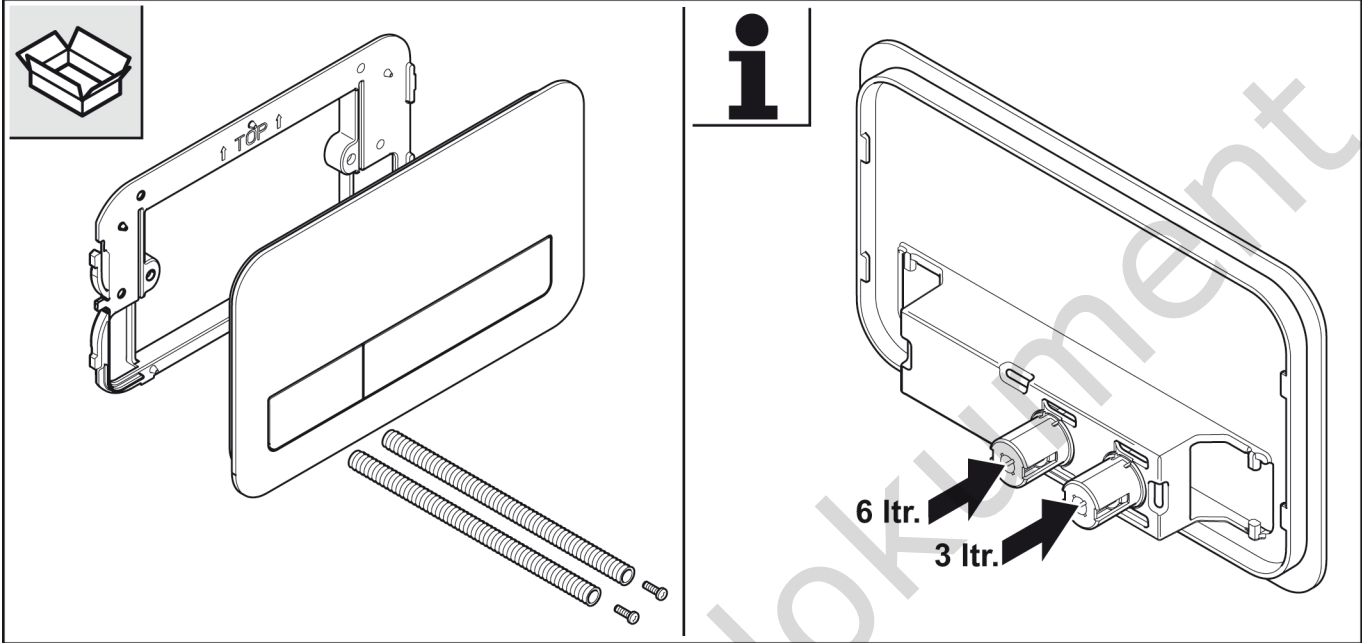

1. Avvitare la piastra di supporto.

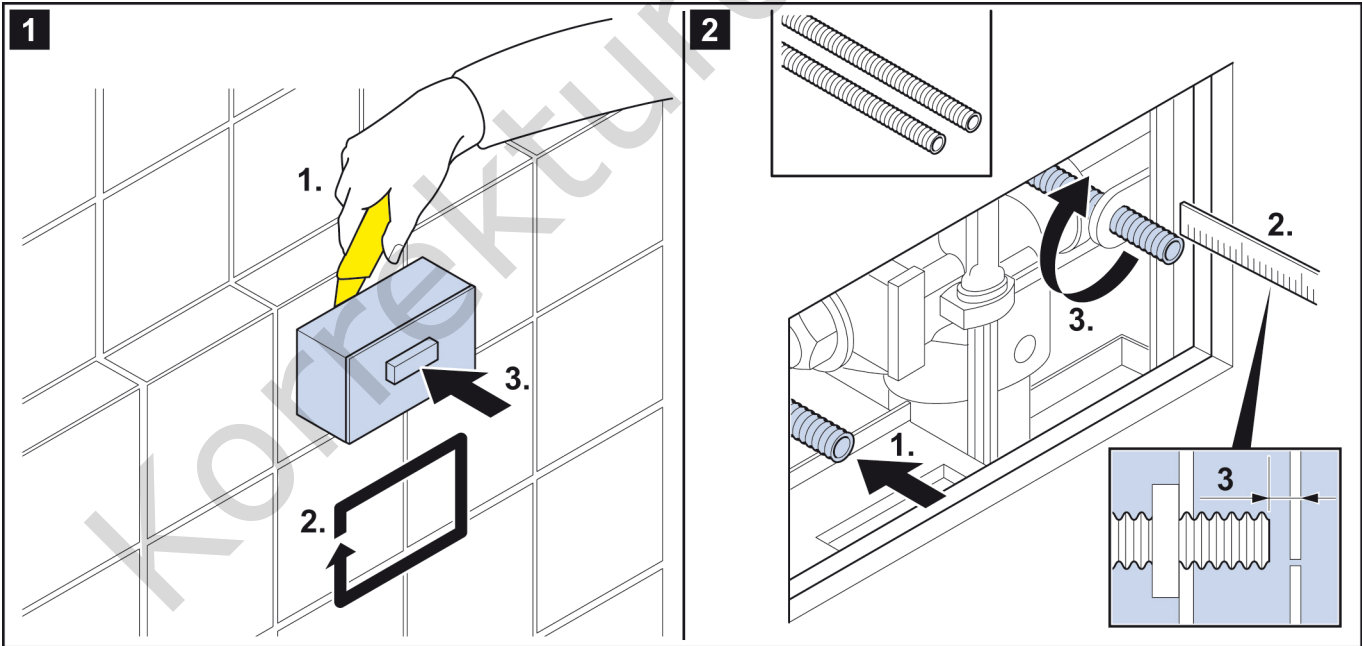

2. Inserire la spina nella presa, vedi fig. 3 e 4.

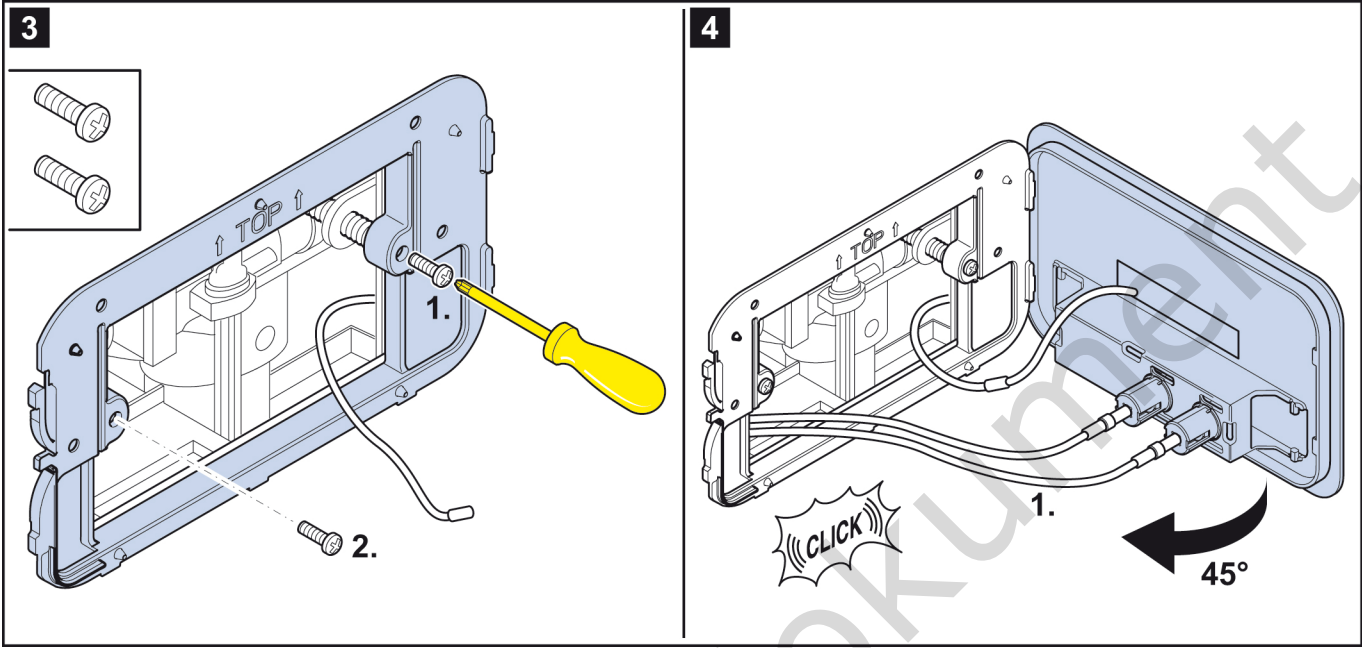

3. Montare la piastra a pressione, vedi fig. 5.

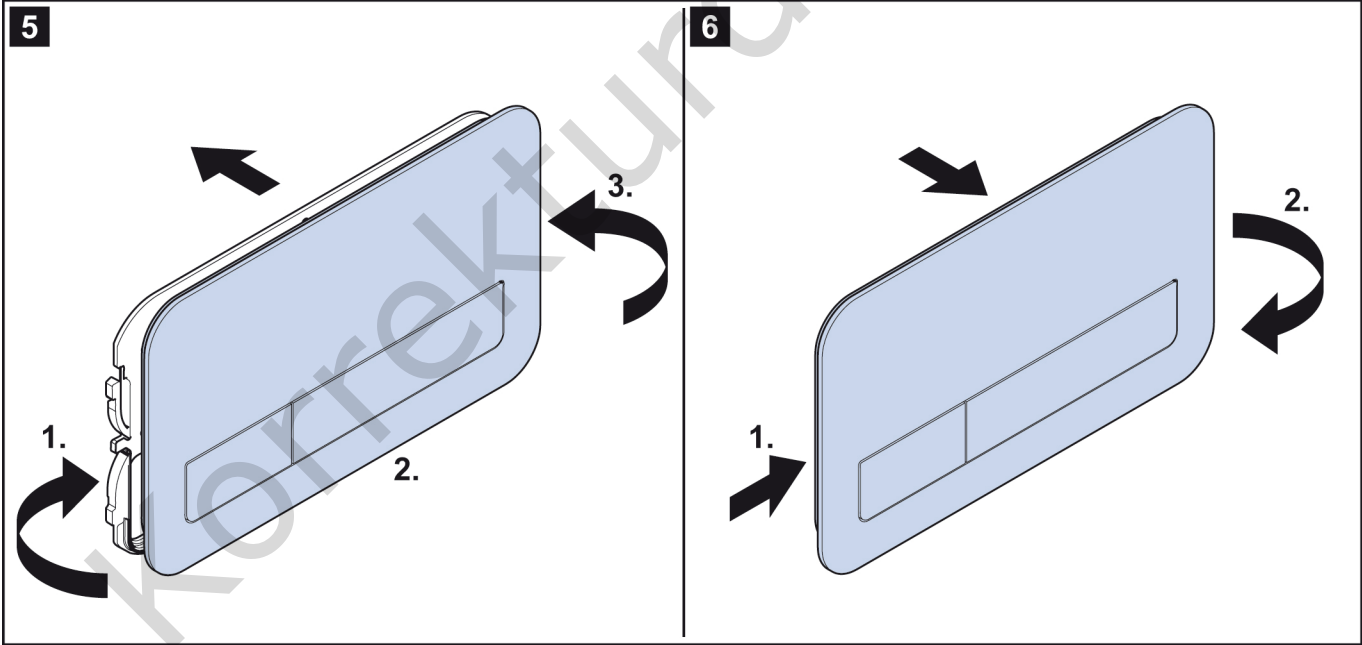

Pulizia

IT

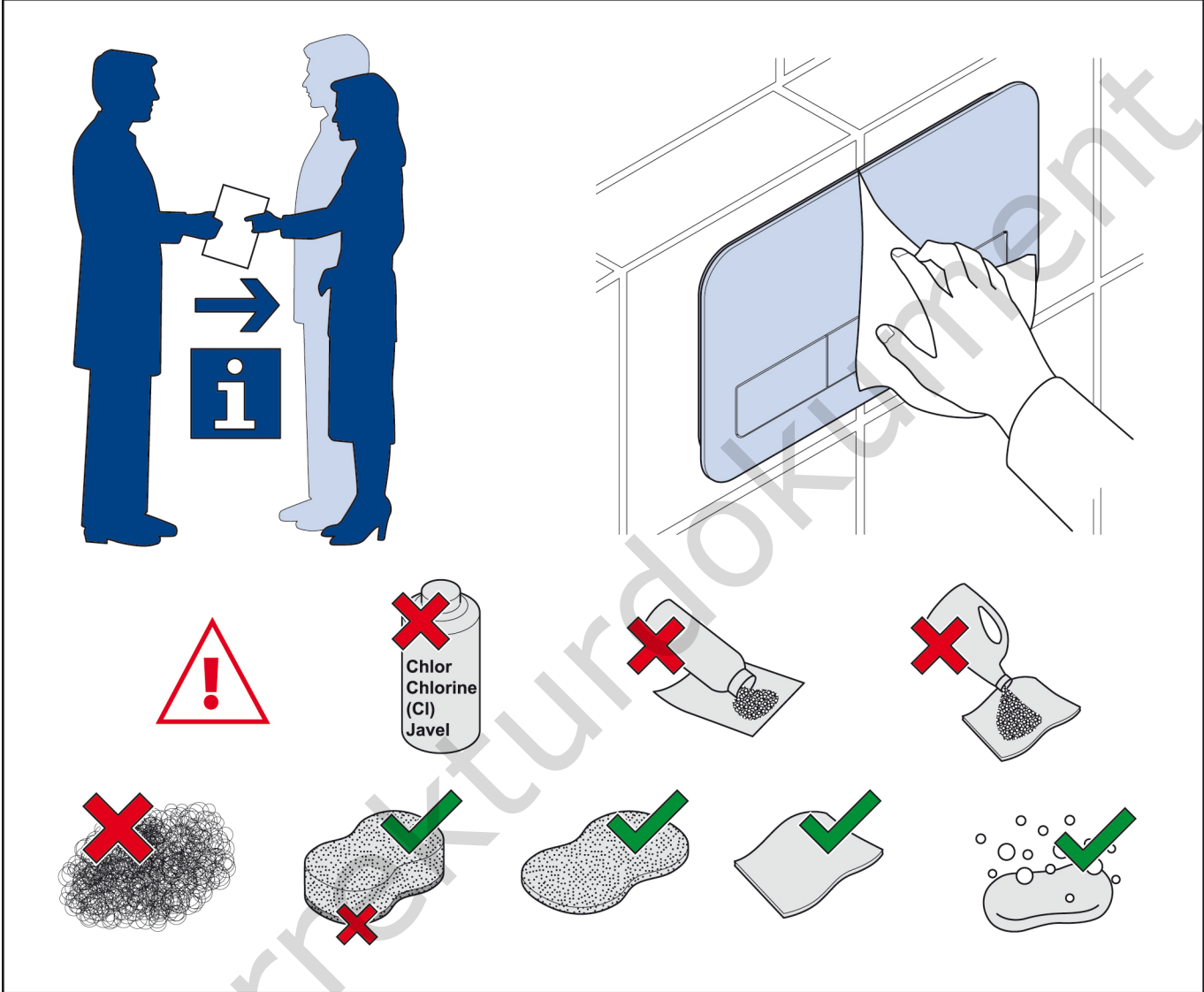

CE

EAC

Безопасность



Предупреждение!

Поражение электрическим током при касании токоведущих компонентов! Следствием могут стать тяжелые травмы вплоть до летального исхода.

- Подключение к сети должны выполнять только квалифицированные электрики.
- Убедитесь в том, что во время выполнения работ линия питания отключена и приняты меры для предотвращения включения.
- Не подключайте и не отключайте сетевой разъем мокрыми руками.

Все работы по электромонтажу должны выполнять только квалифицированные электрики в соответствии с правилами электротехники.

Установка

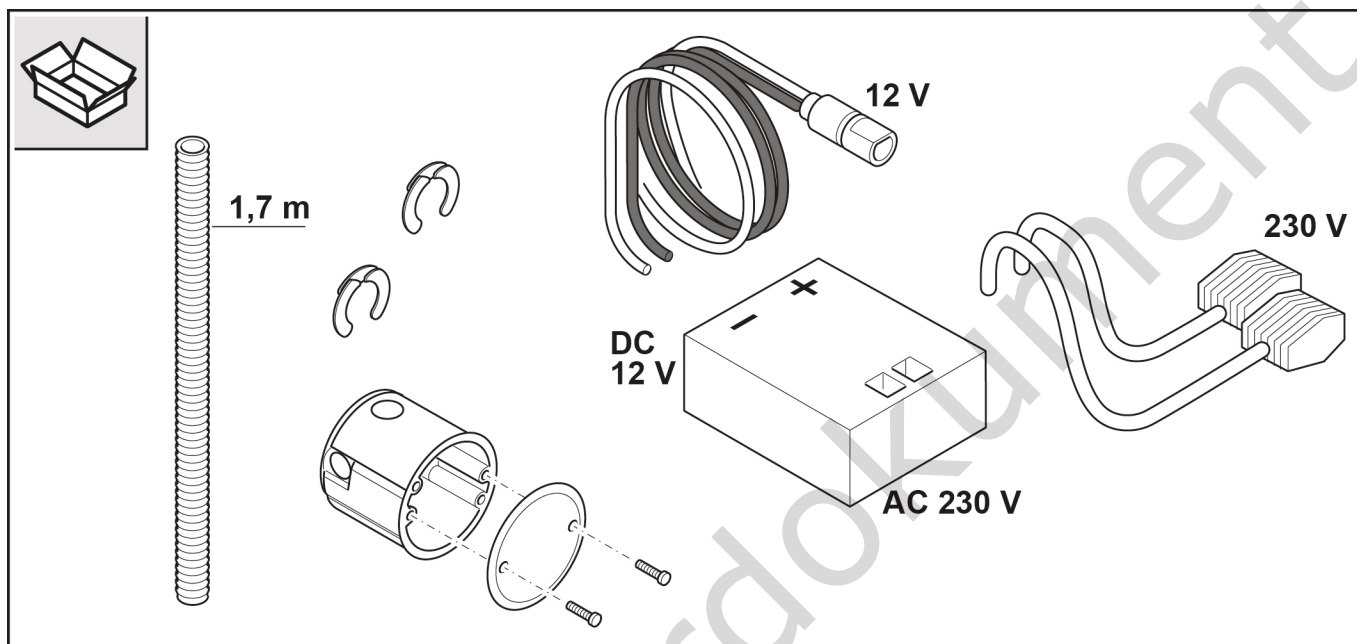

1. Определите место установки коробки для скрытого монтажа.
 ⇒ Мы рекомендуем устанавливать ее под сливным бачком, см. рис. 1.

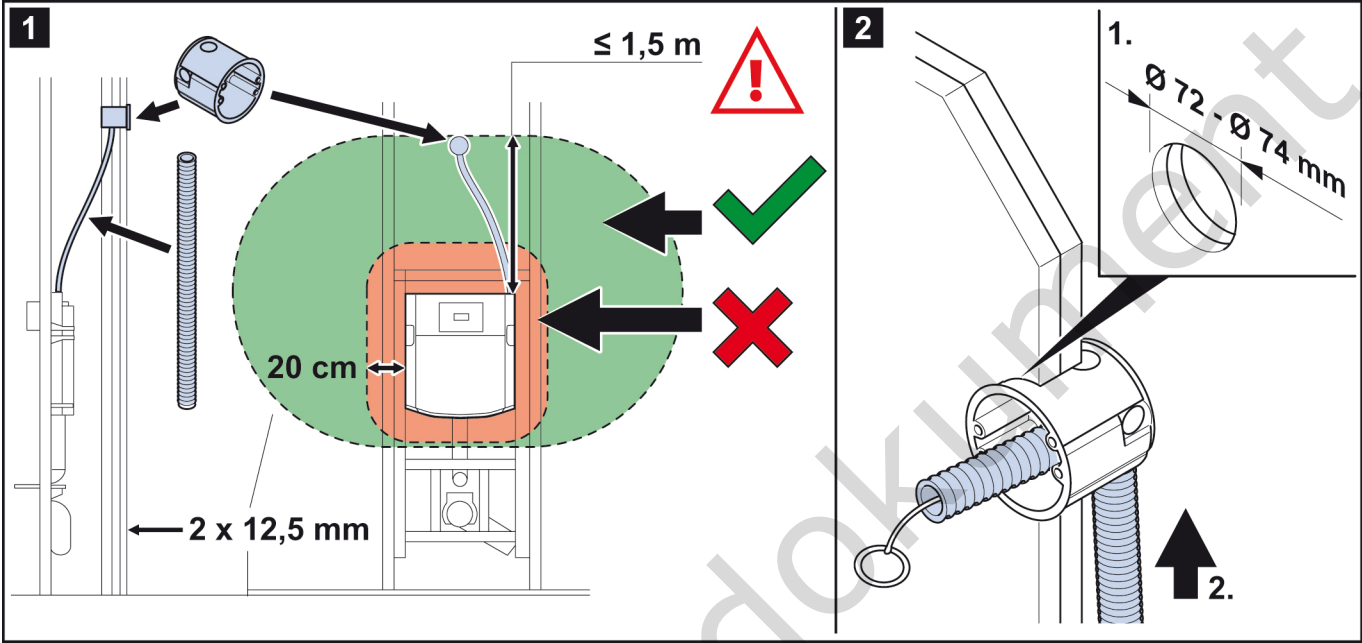

2. Установите коробку для скрытого монтажа.
3. Проложите входящую в комплект поставки полую трубку от коробки для скрытого монтажа к сливному бачку, см. рис. 2.

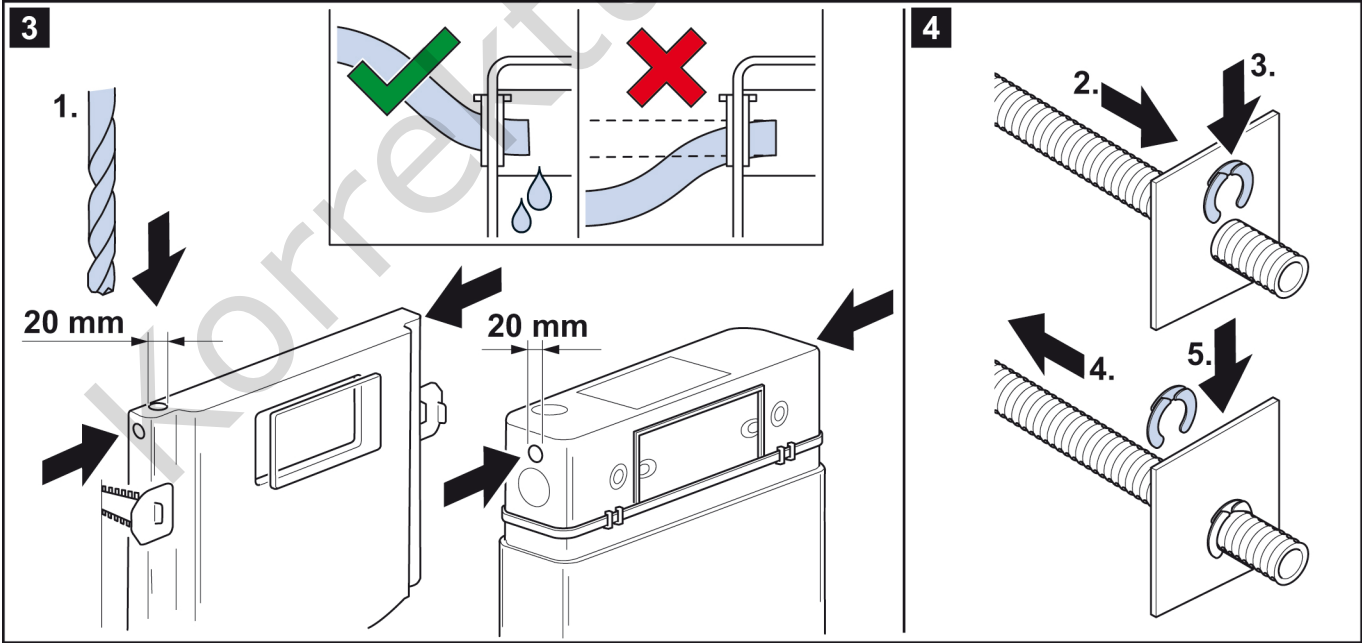

RU

Монтаж панели смыва

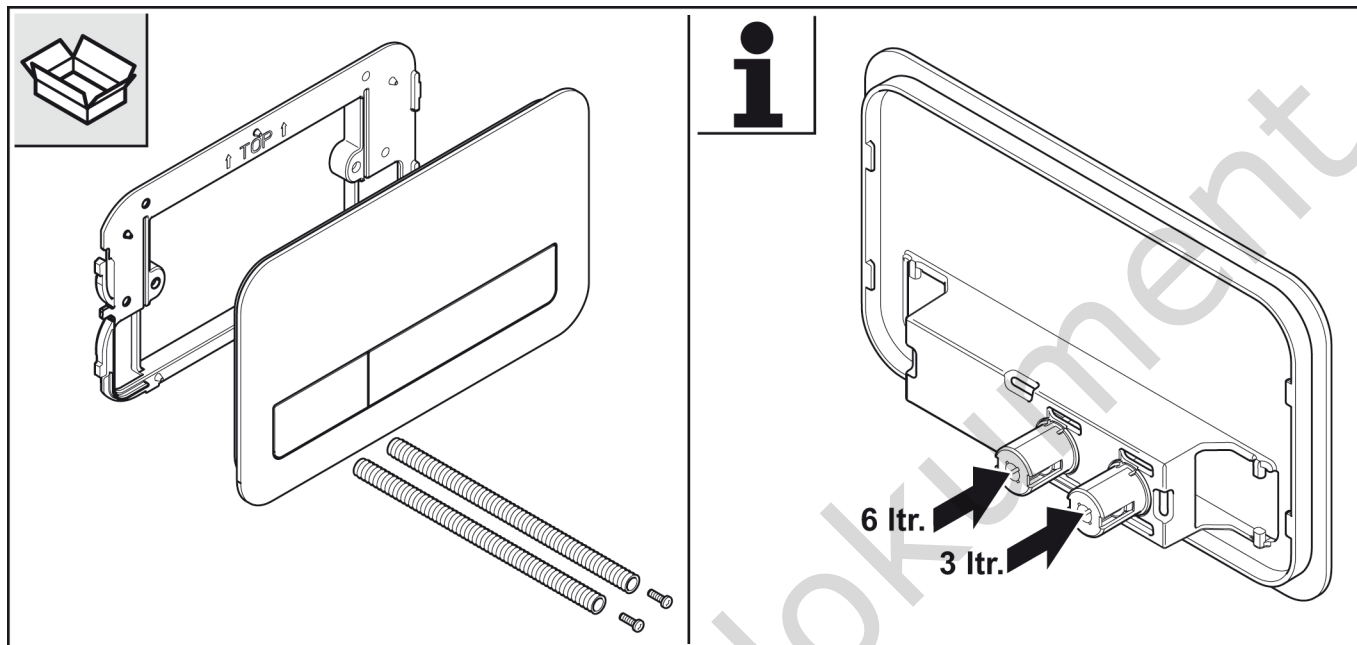

1. Прикрутите основание для панели смыва.

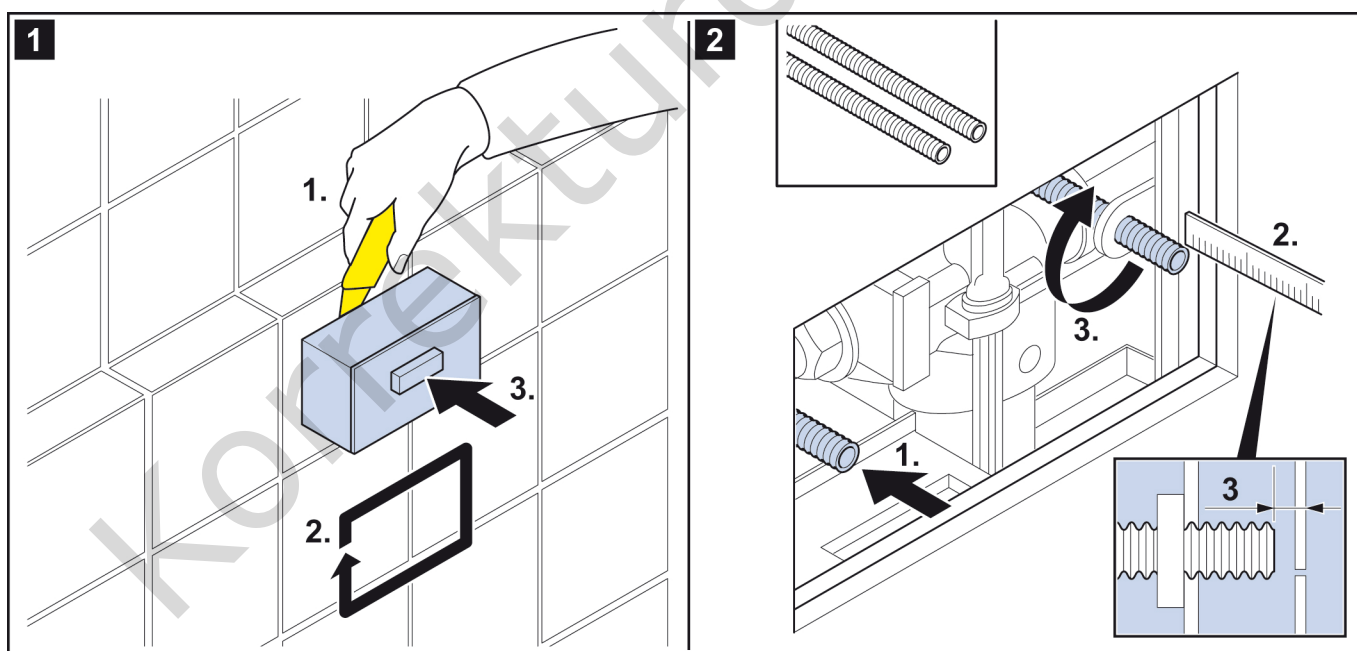

2. Присоедините разъемы к гнездам, см. рис. 3 и 4.

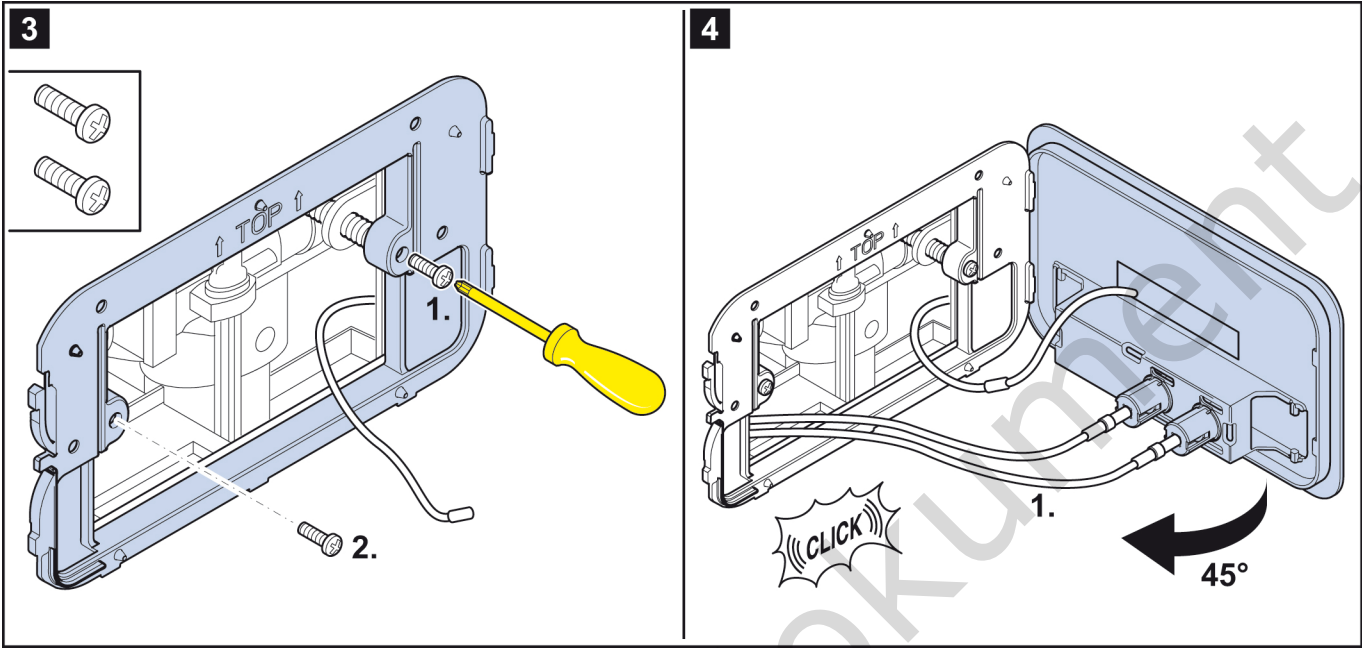

3. Установите панель смыва, см. рис. 5.

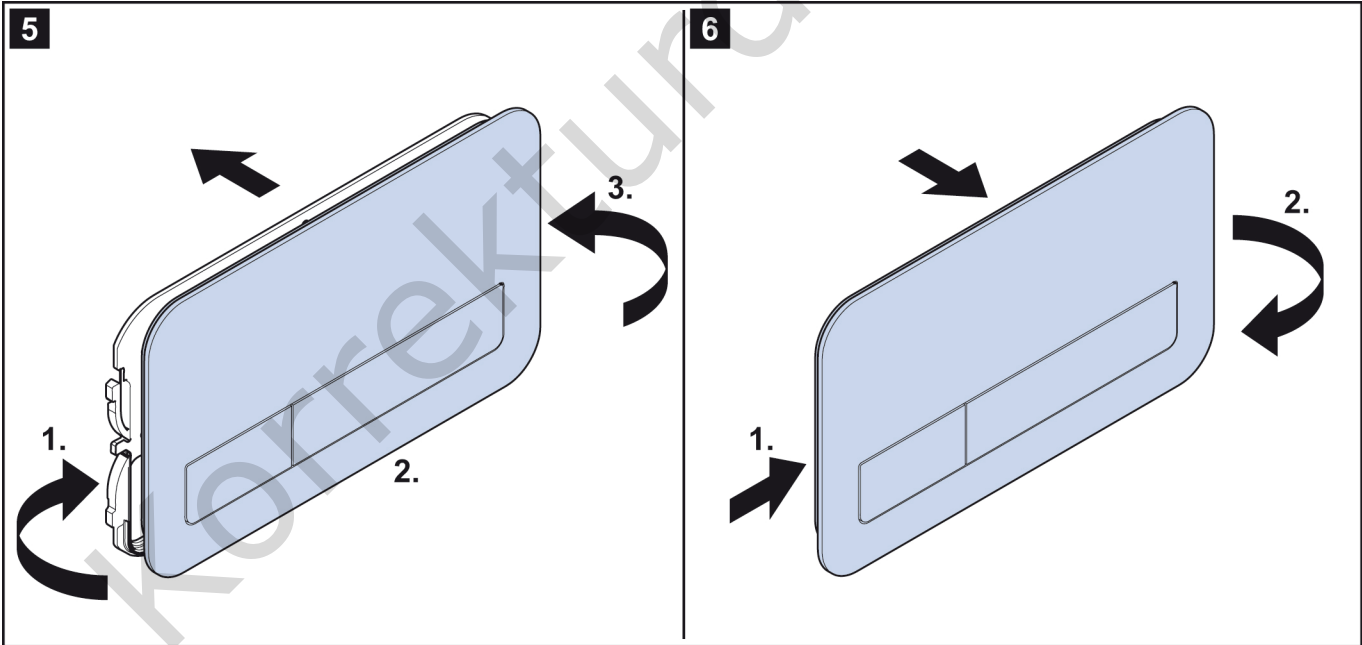

Очистка

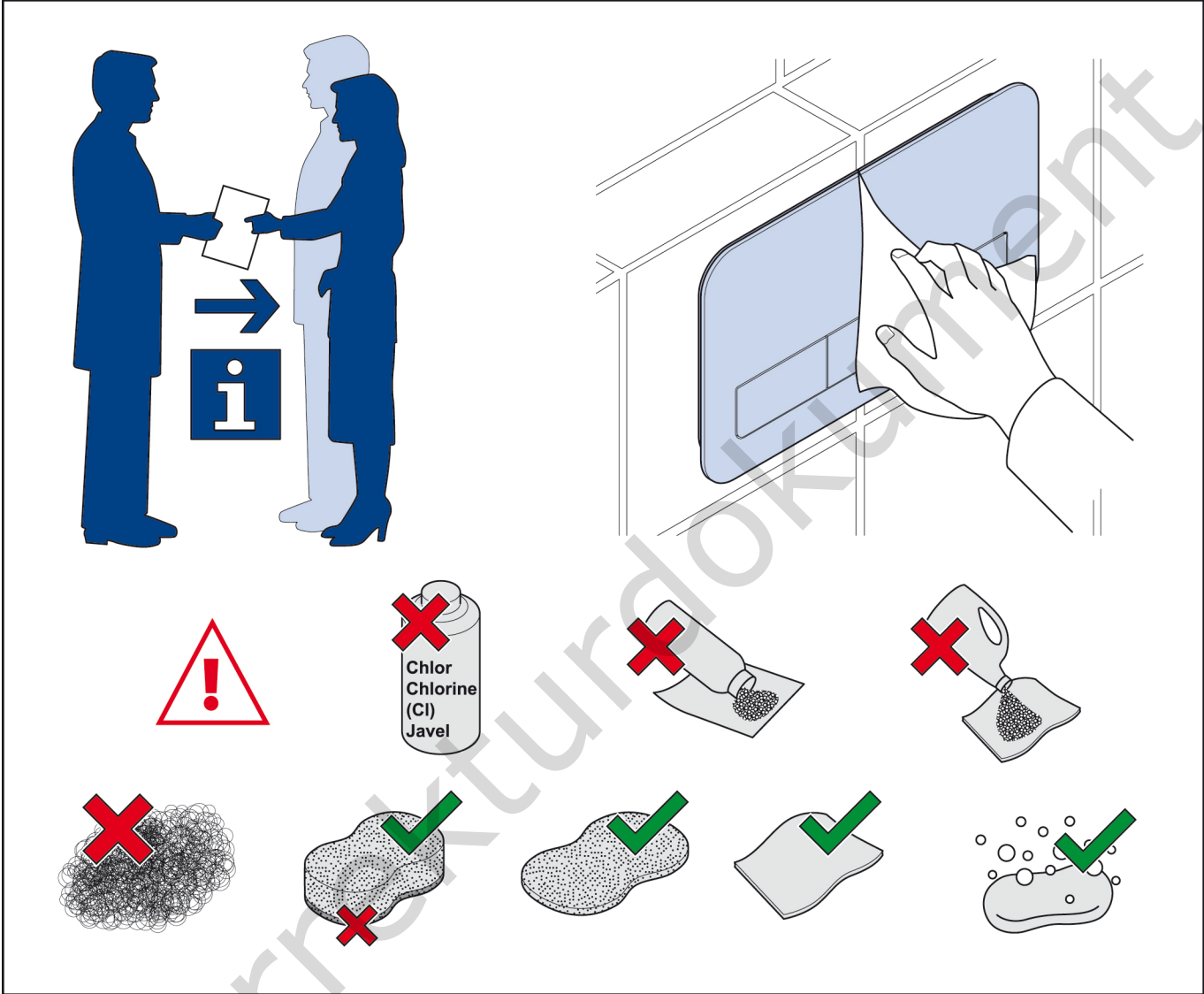

CE

EAC

Korrekturdokument

Korrekturdokument

Korrekturdokument

VILLEROY & BOCH

GERMANY

*Villeroy & Boch AG
Bathroom and Wellness Division
Headquarters
66693 Mettlach
Germany*

*Tel: +49 (0) 68 64 / 81 0
Fax: +49 (0) 68 64 / 81 1484*

Korrekturdokument